

DIXON ZTR[®]

BLACK BEAR[™]

ZTR[®]

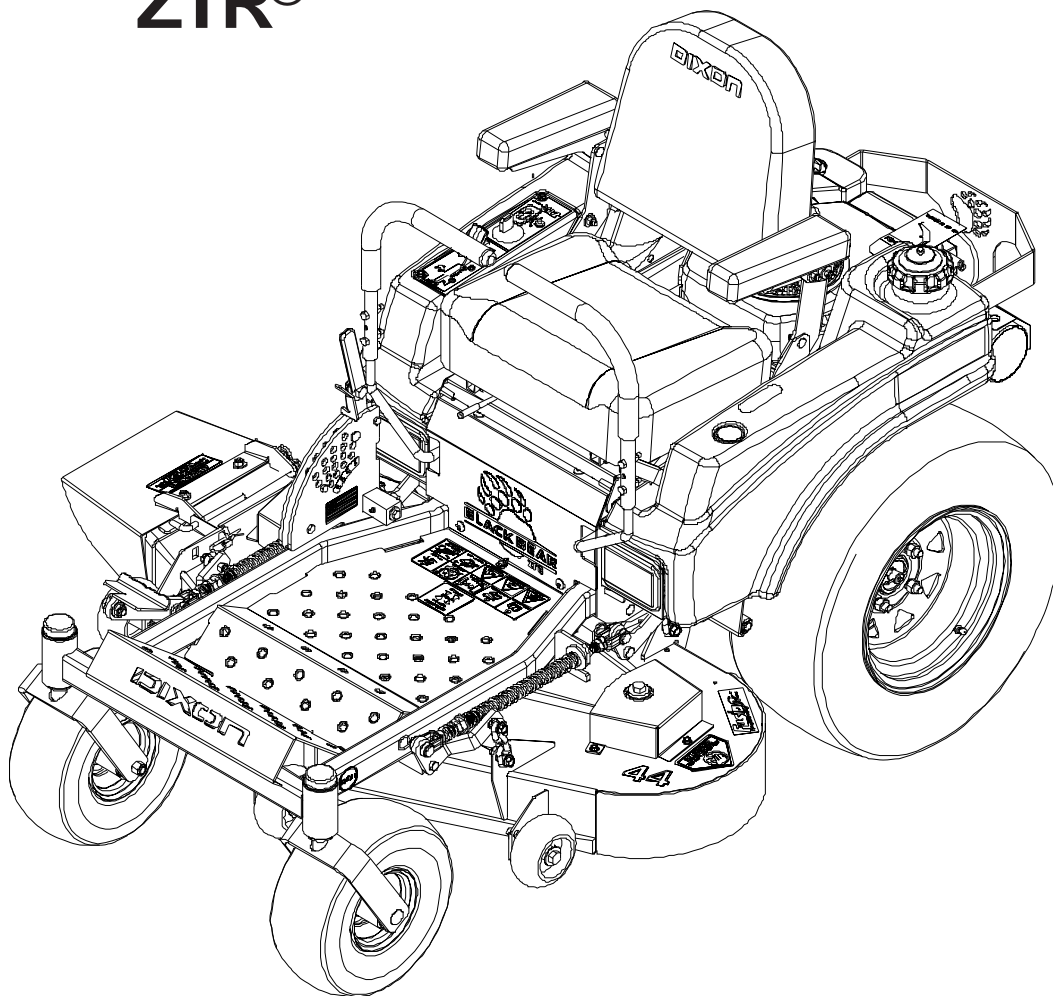

Operator's Manual

ZTR34/968999564

ZTR44/968999565

ZTR34/968999566

ZTR34/968999618

ZTR34/968999619

ZTR44/968999690

ZTR34/968999731

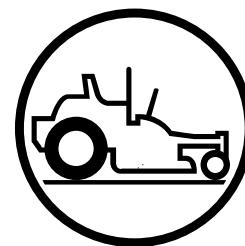

Please read the operator's manual carefully and make sure you understand the instructions before using the machine.

English



WARNING!

Failure to follow cautious operating practices can result in serious injury to the operator or other person. The owner must understand these instructions to operate the mower. Each person operating the mower must be of sound mind and body and must not be under the influence of any mind altering substance.



WARNING!

Engine exhaust, some of its constituents, and certain vehicle components contain or emit chemicals known to the State of California to cause cancer and birth defects or other reproductive harm.



WARNING!

Battery posts, terminals and related accessories contain lead and lead compounds, chemicals known to the State of California to cause cancer and birth defects or other reproductive harm. Wash hands after handling.

CONTENTS

Introduction	4	Maintenance	34
Congratulations	4	Maintenance Schedule	34
Use	4	Battery	36
Good service	5	Ignition System	37
Serial number	5	Checking Safety System	37
Symbols and decals	6	Checking Engine's Cooling Air Intake	38
Translation of instructions	7	Checking & Adjusting Throttle Cable	38
Safety instructions	8	Checking & Adjusting Choke Cable	38
General use	8	Replacing Air Filter	39
Personal Safety	10	Replacing Fuel Filter	40
Operation	10	Checking Fuel Pump's Air Filter	40
Children	11	Checking Tire Pressures	41
Maintenance	12	Checking Parking Brake	41
Movement/Transport	15	Checking V-belts	41
Customer Responsibilities	16	Checking Blades	43
Controls	17	Adjusting Mower Deck	45
Main Components and		Cleaning & Washing	46
Operating Instructions	17	Caster Wheels	47
Operation	24	Hardware	47
Before You Start	25	Lubrication	48
Starting the Engine	25	Lubrication Schedule	48
Start Engine with Weak Battery	28	Troubleshooting	55
Running	29	Storage	58
Operating on Hills	30	Winter Storage	58
Mowing Tips	31	Service	58
Transport	31	Schematic	59
Stopping Engine	32	Technical Data	62
Moving by Hand	33	Conformity Certificates	71
		Service Journal	72
		Delivery Service	72
		After First 8 Hours	73
		25-Hour Service	74
		50-Hour Service	75
		100-Hour Service	76
		300-Hour Service	77
		At Least Once Each Year	78

INTRODUCTION

Congratulations

Thank you for purchasing a Dixon ride-on mower. This machine is built for superior efficiency to rapidly mow primarily large areas. A control panel easily accessible to the operator and a hydrostatic transmission regulated by steering controls both contribute to the machine's performance.

This manual is a valuable document. Read the contents carefully before using or servicing the machine. The following of instructions (use, service, maintenance, etc.) by all who operate this machine is important for the safety of the operator and others. It can also considerably increase the life span of the machine and increase its resale value.

If you sell your machine, be sure to give the operator's manual to the new owner.

The final chapter of this operator's manual provides a Service Journal. Ensure that service and repair work are documented. A well-kept service journal reduces service costs for the maintenance and affects the machine's resale value. Please contact your dealer for more information. Take the operator's manual along when the machine is taken to your dealer for service.

General

In this operator's manual, left and right, backward and forward are used in relation to the machine's normal driving direction.

Continuous dedication to improve our products require that specifications and design are subject to change without notice.

Driving and Transport on Public Roads

Check applicable road traffic regulations before transporting on public roads. If the machine is transported, you must always use approved fastening equipment and ensure that the machine is well anchored. **DO NOT** operate this machine on public roadways.

Towing

Do not tow this machine, it may cause damage to the drive system.

Do not tow any trailers, etc. with this mower. They may jackknife or overturn causing damage to the mower and possible serious injury to the operator.

Operating

This machine is constructed only for mowing grass on lawns and even ground without obstacles such as stones, tree stumps, etc. The machine can also be used for other tasks when equipped with special accessories provided by the manufacturer. Operating instructions for the accessories are provided with delivery. All other types of uses are incorrect. The manufacturer's directions concerning operation, maintenance, and repairs must be carefully followed.

Lawn mowers and all power equipment, can be potentially dangerous if used improperly. Safety requires good judgement, careful use in accordance with these instructions and common sense.

The machine must only be operated, maintained, and repaired by persons familiar with the machine's special characteristics and who are also knowledgeable about the safety instructions. Use only approved repair parts to maintain this machine.

Accident prevention regulations, other general safety regulations, occupational safety rules, and traffic regulations must be followed without fail.

Unauthorized modifications to the design of the machine may absolve the manufacturer from liability for any resulting personal injury or property damage.

INTRODUCTION

Good Service

Dixon's products are sold all over the world and only in specialized retail stores with complete service. This ensures that you as a customer receive only the best support and service. Before the product is delivered, the machine has, for example, been inspected and adjusted by your retailer. See the certificate in the Service Journal in this operator's manual.

When you need spare parts or support in service questions, warranty issues, etc., please consult the following professional:

This Operator's Manual belongs to the machine with the manufacturing number:	Engine	Transmission

Manufacturing Number

The machine's manufacturing number can be found on the printed plate affixed to the left in the engine compartment. Stated on the plate, from the top are:

- The machine's type designation (I.D.).
- The manufacturer's type number (Model).
- The machine's serial number (Serial no.)

Please have the type designation and serial number available when ordering spare parts.

The engine's manufacturing number is stamped on one of the valve covers.

The plate states:

- The engine's model.
- The engine's type.
- Code

Please have these available when ordering spare parts.

The Hydro Drive IZT gears have a barcode decal affixed to the rear of the gears.

SYMBOLS AND DECALS

These symbols are found on the machine and in the operator's manual.
Study them carefully so that you know what they mean.

	<p>WARNING!</p> <p>Xxxx xxxxxx xxxxx xxxx xxxxxxxxxxx xxxxxx xxxxxxxxxxxx. xx xxxxxxxxxxx xxxxx xxxxxxx.</p>
---	---

Used in this publication to notify the reader of a risk of **personal injury or death**, particularly if the reader should neglect to follow instructions given in the manual.

<p>IMPORTANT INFORMATION</p> <p>Xxxx xxxxxx xxxxx xxxx xxxxxxxxxxxx xxxxxx xxxxxxxxxxxx. xx xxxxxxxxxxx xxxx xxxxxx.</p>

Used in this publication to notify the reader of a risk of **material damage**, particularly if the reader should neglect to follow instructions given in the manual. Used also when there is a potential for misuse or misassembly.

R

N



Reverse

Neutral

Fast

Slow

Choke

Fuel

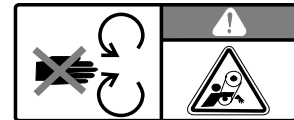
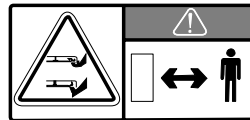

Warning!

Parking Brake

CE conformity marking. Only for European market

Warning! Rotating blades, keep away from the discharge deck

Do not touch parts



Battery acid is corrosive, explosive and flammable

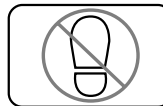

Do not stand here

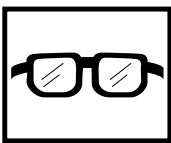

Use protective glasses



Use protective gloves

Noise emissions to the surroundings in accordance with the European Union's directive. The machine's emission is stated in the chapter TECHNICAL DATA and on the decals.

Only machines for European market

SYMBOLS AND DECALS

Read
Operator's
Manual

Shut off engine and
remove key before
performing any
maintenance or repair work

Keep a safe
distance from
the machine

Use on slopes
no greater
than 10°

No passengers

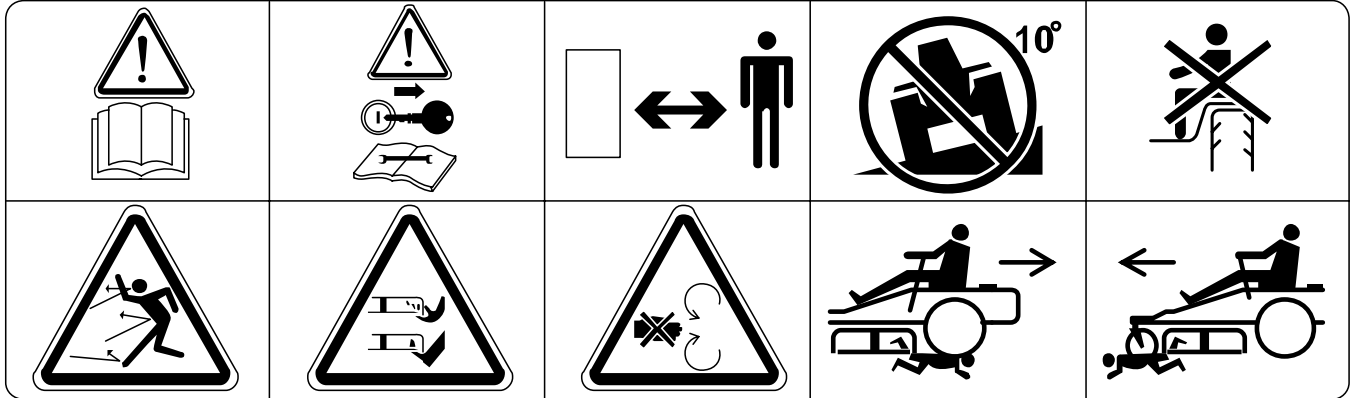

Whole body
exposure to
thrown objects

Severing of fingers
and toes

Do not open or
remove safety
shields while
engine is running

Careful backing up,
watch for other
people

Careful going
forward, watch for
other people



Moving sharp blades under cover

SAFETY

Safety Instructions

These instructions are for your safety. Read them carefully.



WARNING!

This symbol means that important safety instructions need to be emphasized. It concerns your safety.

IMPORTANT: THIS CUTTING MACHINE IS CAPABLE OF AMPUTATING HANDS AND FEET AND THROWING OBJECTS. FAILURE TO OBSERVE THE FOLLOWING SAFETY INSTRUCTIONS COULD RESULT IN SERIOUS INJURY OR DEATH.

General Operation

- Read, understand, and follow all instructions on the machine and in the manual before starting.
- Do not put hands or feet near rotating parts or under the machine. Keep clear of the discharge opening at all times.
- Only allow responsible adults, who are familiar with the instructions, to operate the machine.
- Clear the area of objects such as rocks, toys, wire, etc., which could be picked up and thrown by the blades.
- Be sure the area is clear of bystanders before operating. Stop machine if anyone enters the area.
- Never carry passengers. The machine is only intended for use by one person.
- Do not mow in reverse unless absolutely necessary. Always look down and behind before and while backing.
- Never direct discharged material toward anyone. Avoid discharging material against a wall or obstruction. Material may ricochet back toward the operator. Stop the blades when crossing gravel surfaces.
- Do not operate machine without the entire grass catcher, discharge guard, or other safety devices in place and working
- Slow down before turning.

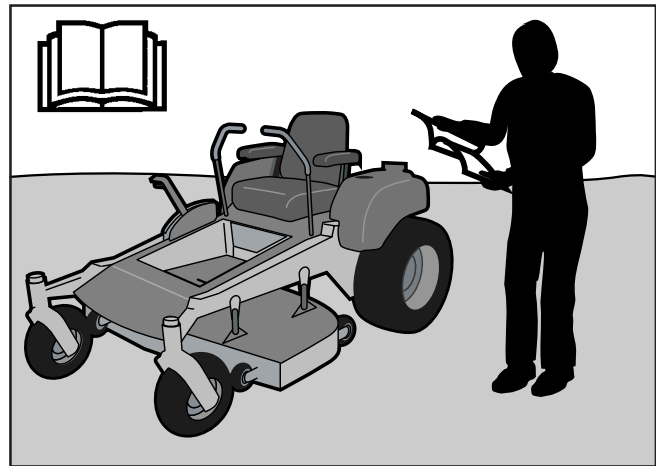

8011-512

Read the operator's manual before starting the machine

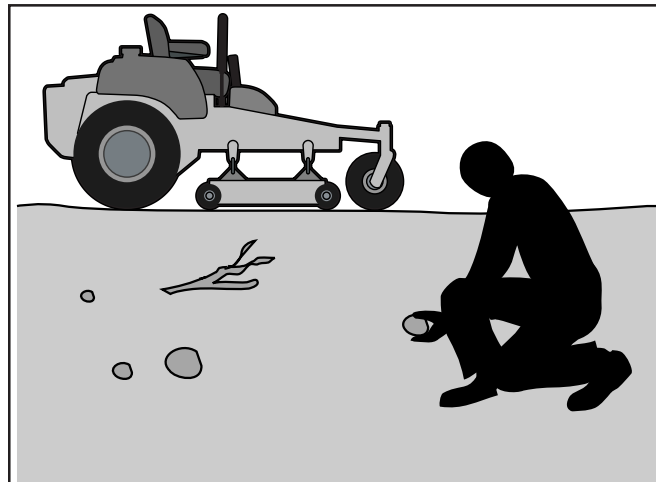

8011-513

Clear the area of objects before mowing

SAFETY

- Never leave a running machine unattended. Always turn off blades, set parking brake, stop engine, and remove keys before dismounting.
- Disengage blades when not mowing. Shut off engine and wait for all parts to come to a complete stop before cleaning the machine, removing the grass catcher, or unclogging the discharge guard.
- Operate machine only in daylight or good artificial light.
- Do not operate the machine while under the influence of alcohol or drugs.
- Watch for traffic when operating near or crossing roadways.
- Use extra care when loading or unloading the machine into a trailer or truck.
- Always wear eye protection when operating machine.
- Data indicates that operators, age 60 years and above, are involved in a large percentage of riding mower-related injuries. These operators should evaluate their ability to operate the riding mower safely enough to protect themselves and others from serious injury.
- Follow the manufacturer's recommendation for wheel weights or counterweights.
- Anyone who operates this machine must first read and understand this Operation Manual. Local laws may regulate the age of the user.
- Keep machine free of grass, leaves or other debris buildup which can touch hot exhaust / engine part and burn. Do not allow the mower deck to plow leaves or other debris which can cause buildup to occur. Clean any oil or fuel spillage before operating or storing the machine. Allow machine to cool before storage.



Never take passengers

8011-520



WARNING!

Engine exhaust and certain vehicle components contain or emit chemicals considered to cause cancer, birth defects, or other reproductive system damage. The engine exhaust contains carbon monoxide, which is a odorless, colorless, poisonous gas. Do not use the machine in enclosed spaces.

SAFETY

Personal Safety Equipment



WARNING!

When using the machine, approved personal protective equipment (shown in illustrations) shall be used. Personal protective equipment cannot eliminate the risk of injury but it will reduce the degree of injury if an accident does happen. Ask your retailer for help in choosing the right equipment.

- Make sure that you have first aid equipment close at hand when using the machine.
- Never use the machine when barefoot.
- Always wear protective shoes or boots, preferably with steel toe caps.
- Always wear approved protective glasses or a full visor when assembling or driving.
- Always wear gloves when handling the blades.
- Never wear loose clothing that can get caught in moving parts.
- Use ear protectors to avoid damage to hearing.

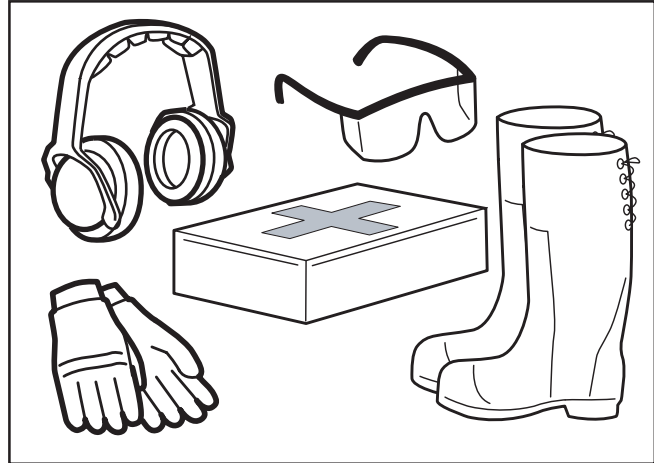

8011-670a

Personal protective equipment

Slope Operation

Slopes are a major factor related to loss of control and tip-over accidents, which can result in severe injury or death. Operation on all slopes requires extra caution. If you cannot back up the slope or if you feel uneasy on it, do not mow it.

- Mow up and down slopes (10 degrees maximum), not across.
- Watch for holes, ruts, bumps, rocks, or other hidden objects. Uneven terrain could overturn the machine. Tall grass can hide obstacles.
- Choose a low ground speed so that you will not have to stop while on the slope.
- Do not mow on wet grass. Tires may lose traction.
- Avoid starting, stopping, or turning on a slope. If the tires lose traction, disengage the blades and proceed slowly straight down the slope.
- Keep all movement on the slopes slow and gradual. Do not make sudden changes in speed or direction, which could cause the machine to roll over.

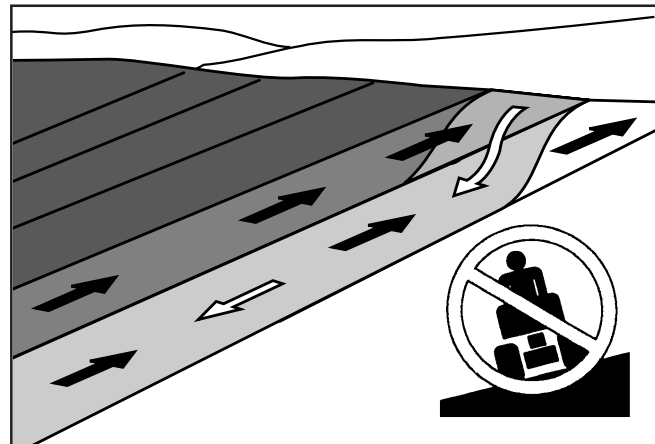

6003-004

Mow up and down, not side to side



WARNING!

Do not drive up or down hills with slopes greater than 10 degrees. And do not drive across any slopes.

SAFETY

- Use extra care while operating machine with grass catchers or other attachments; they can affect the stability of the machine. Do not use on steep slopes.
- Do not try to stabilize the machine by putting your foot on the ground.
- Do not mow near drop-offs, ditches, or embankments. The machine could suddenly roll over if a wheel is over the edge or if the edge caves in.

Children

Tragic accidents can occur if the operator is not alert to the presence of children. Children are often attracted to the machine and the mowing activity. *Never* assume that children will remain where you last saw them.

- Keep children out of the mowing area and in the watchful care of a responsible adult other than the operator.
- Be alert and turn machine off if a child enters the area.
- Before and while backing, look behind and down for small children.
- Never carry children, even with the blades shut off. They may fall off and be seriously injured or interfere with safe machine operation. Children who have been given rides in the past may suddenly appear in the mowing area for another ride and be run over or backed over by the machine.
- Never allow children to operate the machine.
- Use extra care when approaching blind corners, shrubs, trees, or other objects that may block your view of a child.

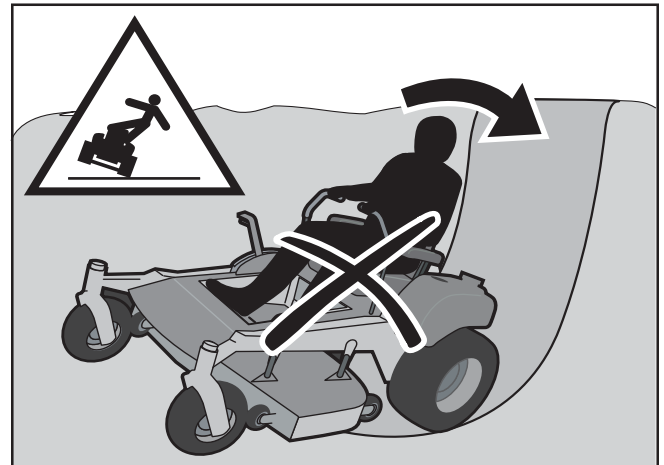

8011-509

Be extra cautious when driving on slopes

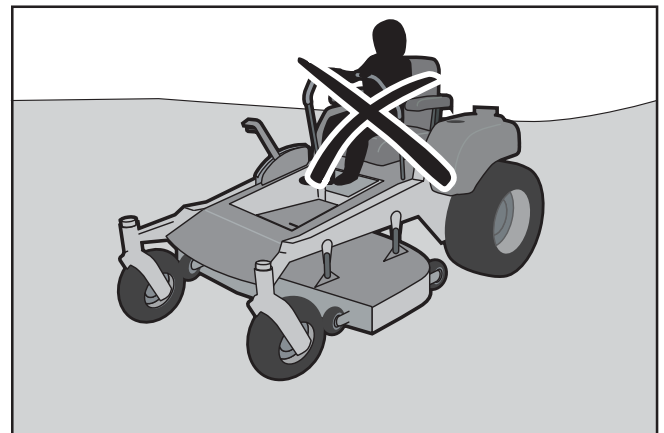

8011-517

Never allow children to operate the machine



8011-518

Keep children away from work area

SAFETY

Maintenance



WARNING!

The engine must not be started when the driver's floor plate or any protective plate for the mower deck's drive belt is removed.

Safe Handling of Gasoline

To avoid personal injury or property damage, use extreme care in handling gasoline. Gasoline is extremely flammable and the vapors are explosive.

- Extinguish all cigarettes, cigars, pipes, and other sources of ignition.
- Use only approved gasoline container.
- Never remove gas cap or add fuel with the engine running. Allow engine to cool at least two (2) minutes before refueling.
- Never fuel the machine indoors.
- Never store the machine or fuel container where there is an open flame, spark, or pilot light such as on a water heater or other appliances.
- Before you begin refueling, minimize the risk of static electricity by touching a metal surface.
- Never fill containers inside a vehicle or on a truck or trailer bed with plastic liner. Always place containers on the ground away from your vehicle when filling.
- Remove gas-powered equipment from the truck or trailer and refuel it on the ground. If this is not possible, then refuel such equipment with a portable container, rather than from a gasoline dispenser nozzle.
- Keep the nozzle in contact with the rim of the fuel tank or container opening at all times until fueling is complete. Do not use a nozzle lock-open device.
- If fuel is spilled on clothing, change clothing immediately.
- Never overfill fuel tank. Replace gas cap and tighten securely.
- Do not start the engine near spilled fuel.
- Never use gasoline as a cleaning agent.
- If leaks arise in fuel system, engine must not be started until problem has been resolved.
- Check the fuel level before each use and leave space for the fuel to expand, because the heat from the engine and the sun may otherwise cause the fuel to expand and overflow.



8011-516

Never fill the fuel tank indoors



WARNING!

The engine and the exhaust system, become very hot during operation.

Risk for burns if touched.

Allow engine and exhaust system to cool at least two (2) minutes before refueling.

SAFETY

General Maintenance

- Never operate machine in a closed area.
- Keep all nuts and bolts tight to be sure the equipment is in safe working condition.
- Never tamper with safety devices. Check their proper operation regularly.
- Keep machine free of grass, leaves, or other debris buildup. Clean oil or fuel spillage and remove any fuel-soaked debris. Allow machine to cool before storing.
- If you strike a foreign object, stop and inspect the machine. Repair, if necessary, before restarting.
- Never make any adjustments or repairs with the engine running.
- Check grass catcher components and the discharge guard frequently and replace with manufacturer's recommended parts, when necessary.
- Mower blades are sharp. Wrap the blade or wear gloves, and use extra caution when servicing them.
- Check brake operation frequently. Adjust and service as required.
- Maintain or replace safety and instruction labels, as necessary.
- Do not modify safety equipment. Check regularly to be sure it works properly. The machine must not be driven with defective or unmounted protective plates, protective cowlings, safety switches, or other protective devices.
- Do not change the settings of governors and avoid running the engine with overly high engine speeds. If you run the engine too fast, you risk damaging the machine components.
- Be very careful when handling battery acid. Acid on skin can cause serious corrosive burns. If you spill battery acid on your skin, rinse immediately with water.
- Acid in the eyes can cause blindness, contact a doctor immediately.
- Be careful when servicing the battery. Explosive gases form in the battery. Never perform maintenance on the battery when smoking or near open flames or sparks.
- The battery can explode and cause serious injury/damage.

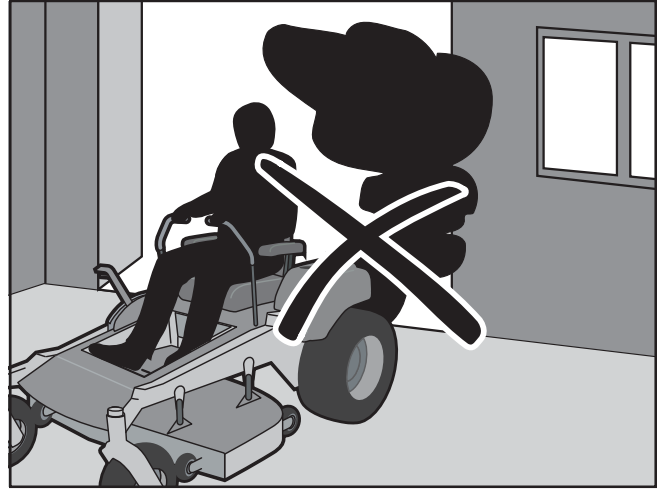

8011-515

Never drive the machine in an enclosed space

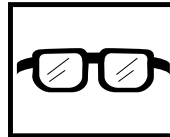

Use protective glasses for maintenance work.



WARNING!

The battery contains lead and lead compounds, chemicals that are considered to cause cancer, birth defects, and other reproductive system damage. Wash your hands after handling the battery.

SAFETY

- Ensure that nuts and bolts, especially the fastening bolts for the blade attachments, are properly tightened, torqued and that the equipment is in good condition.
- Do not modify safety equipment. Check regularly to be sure it works properly. The machine must not be driven with defective or unmounted protective plates, protective cowlings, safety switches, or other protective devices.
- Do not change the settings of governors and avoid running the engine with overly high engine speeds. If you run the engine too fast, you risk damaging the machine components.
- Sparking can occur when working with the battery and the heavy cables of the starter circuit. This can cause battery explosion, fire or eye injury. Sparking in this circuit can not occur after the chassis cable (normally negative, black) is removed from the battery.

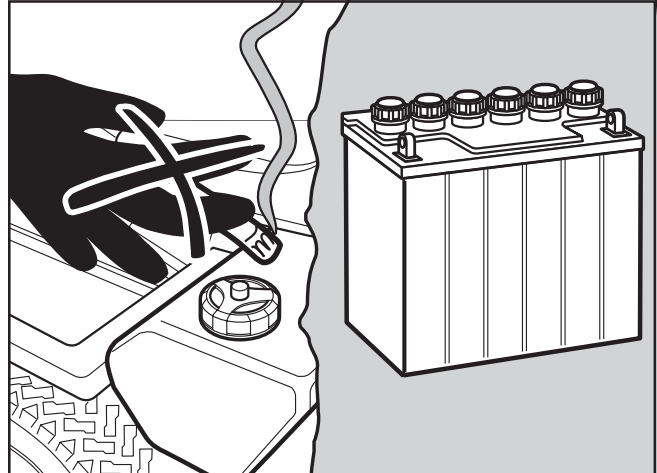

6003-009

Do not smoke when performing maintenance on the battery. The battery can explode and cause serious injury/damage.



WARNING!

Avoid electrical sparking and its consequences by the following routines:

- Use protective goggles.
- Ensure that the fuel filler cap is mounted tightly and no flammable substances is stored in an open vessel.
- Never work with the starter circuit if there is spilled fuel.
- Disconnect the chassis cable from the battery first and reconnect it last.
- Do not make a bridge short circuit across the starter relay to run the starter.
- Never use the machine indoors or in spaces lacking proper ventilation. The exhaust fumes contain carbon monoxide, an odorless, poisonous, and lethal gas.
- Stop and inspect the equipment if you run over or into anything. If necessary, make repairs before starting.
- Never make adjustments with the engine running.
- The machine is tested and approved only with the equipment originally provided or recommended by the manufacturer. Only use approved repair parts for the machine.

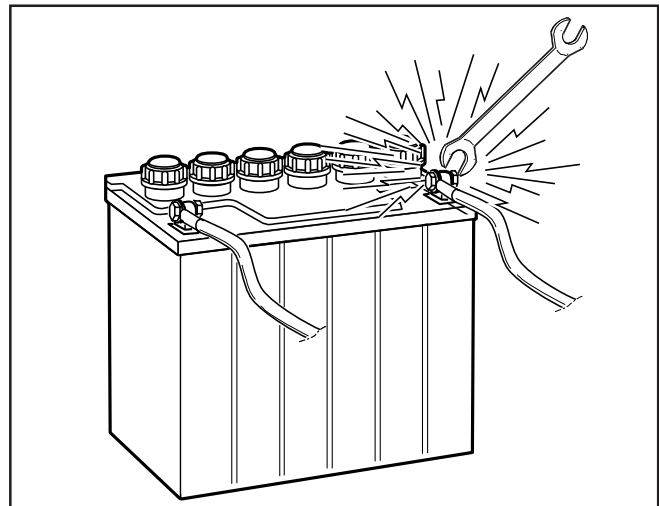

8009-728

Risk of sparking

SAFETY

- The blades are sharp and can cause cuts and gashes. Wrap the blades or use protective gloves when handling them.
- Check the parking brake's functionality regularly. Adjust and service as necessary.
- The mulch blades should only be used in familiar areas when higher quality mowing is desired.
- Reduce the risk of fire by removing grass, leaves, and other debris that may have accumulated on the machine. Allow the machine to cool before putting it in storage.
- Regularly clean deck and underside of deck, avoid spraying engine and electrical components with water.

Transport

- The machine is heavy and can cause serious crushing injuries. Be extra cautious when it is loaded on or unloaded from a vehicle or trailer.
- Use an approved trailer to transport the machine. Activate the parking brake, turn off the fuel supply, and fasten the machine with approved fastening devices, such as bands, chains, or straps, when transporting.
- Do not operate this machine on public roadways.
- Check and abide by local traffic regulations before transporting the machine on any road.
- Do not tow this machine, it may cause damage to the drive system.
- Do not tow any trailers, etc. with this mower. They may jackknife or overturn causing damage to the mower and possibly serious injury to the operator.

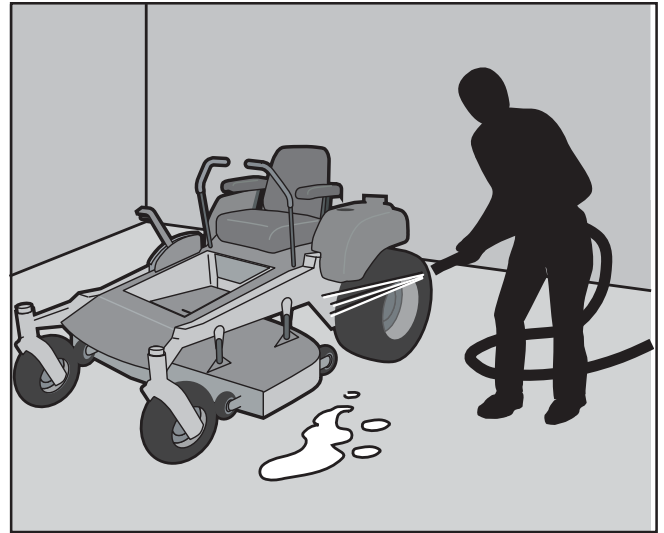

8011-515

Never drive the machine in an enclosed space



WARNING!

Escaping hydraulic oil under pressure can have sufficient force to penetrate the skin, causing serious injury. If injured by escaping fluid, see a doctor at once. Serious infection or reaction can develop if proper medical treatment is not administered immediately.

IMPORTANT INFORMATION

The parking brake is not sufficient to lock the machine in place during transport. Ensure that the machine is well fastened to the transport vehicle. Always reverse the machine onto the transport vehicle to avoid tipping it over.

SAFETY

Roll over Protection system (ROPS)

The ROPS increases the basic weight of the unit by 42 lbs/19 kg. The ROPS on the US units are standard, on the European units is the ROPS an accessory.

- Do not use ROPS as a lifting, attaching or anchoring point.
- Do not use ROPS for wrecking or towing.
- Do not exceed Max GVW: 2822 lbs/1283 kg.
- Read machine operator's manual before each use.
- Securely fasten your seat belt if the unit has a ROPS.
- Where possible, avoid operating the unit near ditches, embankments and holes.
- Reduce speed when turning, crossing slopes and on rough, slick or muddy surfaces.
- Stay off slopes too steep for safe operation.
- Watch where you are going, especially at row ends, on roads and around trees.
- Do not permit others to ride.
- Operate the mower smoothly - no jerky turns, starts or stops.
- When mower is stopped, set brakes securely and use park brake.
- If any part of ROPS is damaged, the entire ROPS must be replaced.
- Check all bolts including seat belt for correct torque before each use.
- Check ROPS structure for damage before each use.
- ROPS bar is NOT intended for use in sub zero temperatures.

Customer responsibilities

- Read and observe the safety rules.
- Follow a regular schedule in maintaining, caring for and using your mower.
- Follow the instructions under "Maintenance" and "Storage" sections of this owner's manual.

A spark arrester for the muffler is available through your authorized Husqvarna dealer.



WARNING!

The structures capability may be impaired by structural damage if overturned, or alteration occurs. If any of these conditions take place, the total structure MUST be replaced.



WARNING!

This mower is equipped with an internal combustion engine and should not be used on or near any unimproved forest-covered, bush-covered or grass-covered land unless the engine's exhaust system is equipped with a spark arrester meeting applicable local or state laws (if any). If a spark arrester is used, it should be maintained in effective working order by the operator.

CONTROLS

Controls

This operator's manual describes the Dixon Zero Turn Rider. The rider is fitted with a Kawasaki four-stroke V-Twin engine developing 17-19 horse power.

Transmission from the engine is made via two belt-driven hydraulic pumps, which in turn drive a hydraulic motor for each drive wheel. Using the left and right steering controls, the flow is regulated and thereby the direction and speed.

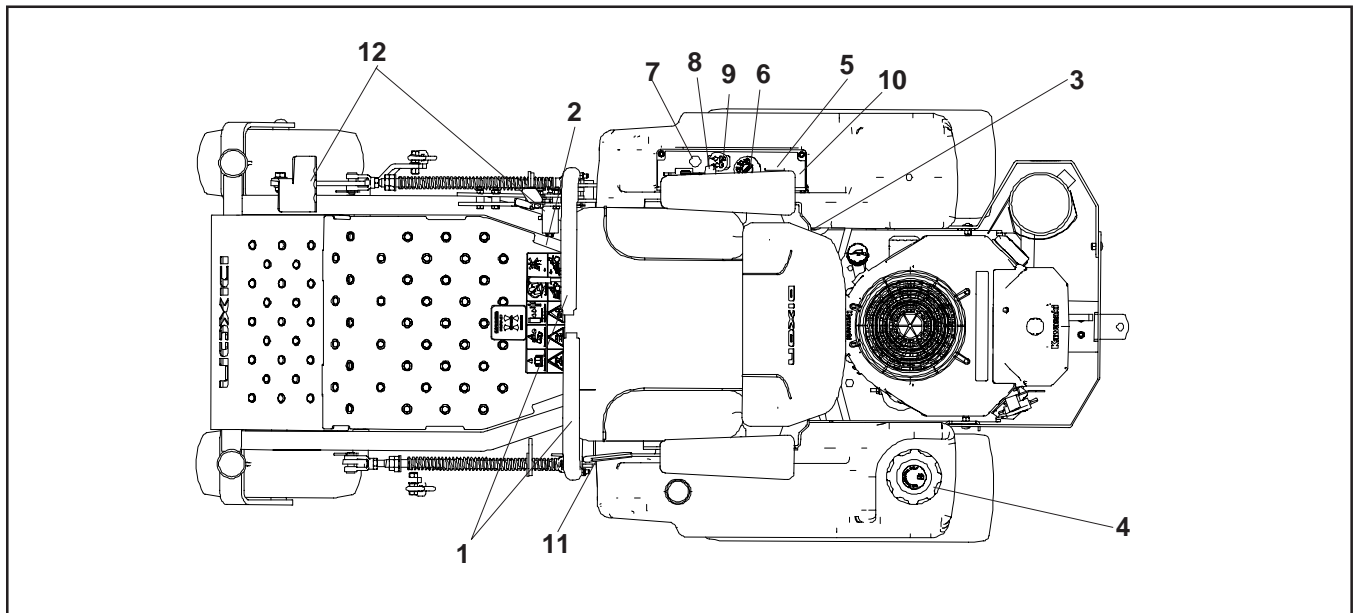
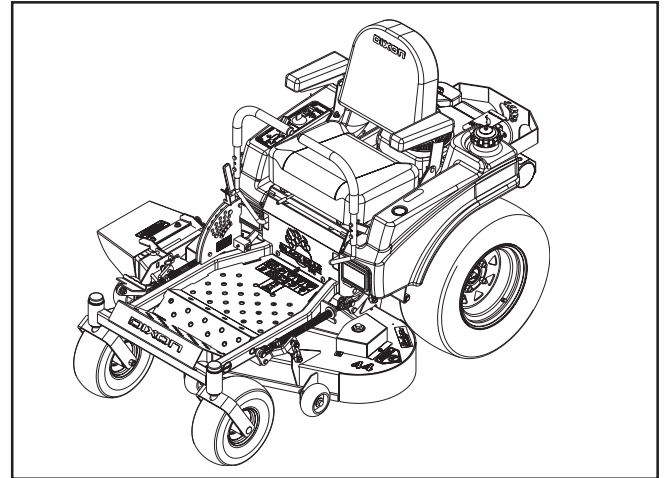

- | | |
|--------------------------|--|
| 1. Motion Control Levers | 7. Choke Control |
| 2. Seat Adjustment Lever | 8. Throttle Control |
| 3. Bypass Linkages | 9. Blade Switch |
| 4. Fuel Tank | 10. Circuit Breaker |
| 5. Hour Meter | 11. Parking Brake |
| 6. Ignition Switch | 12. Cutting Height Lift Lever & Foot Pedal |

CONTROLS

1. Motion Control Levers

The machine's speed and direction are continuously variable using the two steering controls. The steering controls can be moved forward or backward about a neutral position. Furthermore, there is a neutral position, which is locked if the steering controls are moved outward.

When both controls are in the neutral position (N), the machine stands still.

By moving both controls an equal amount forward or backward, the machine moves in a straight line forward or backward respectively.

In order, for example, to turn right while moving forward, move the right control towards the neutral position. The rotation of the right wheel is reduced and the machine turns to the right.

Zero turn can be achieved by moving one control backward (behind the neutral position) and carefully moving the other steering control forward from its neutral position. The rotation direction when zero turning is determined by which steering control is moved backward behind the neutral position. If the left steering control is pulled backward, the machine turns to the left. Use extra care when using this maneuver.

Tracking

If the mower is not tracking straight, check the air pressure in both rear tires. Recommended air pressure is 15 psi (1 bar). Tracking must be checked on a flat and level concrete or blacktop surface. If unit still does not track straight, contact a Dixon dealer for adjustment.

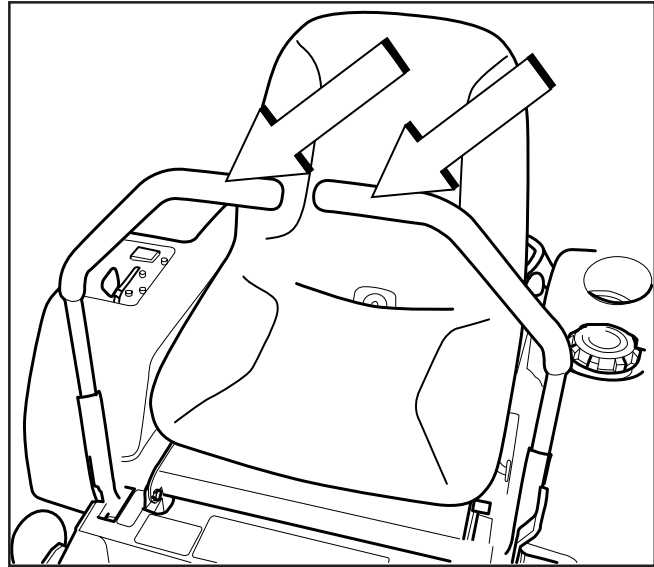

8050-106

Steering controls



WARNING!

The machine can turn very rapidly if one steering control is moved much further forward than the other.

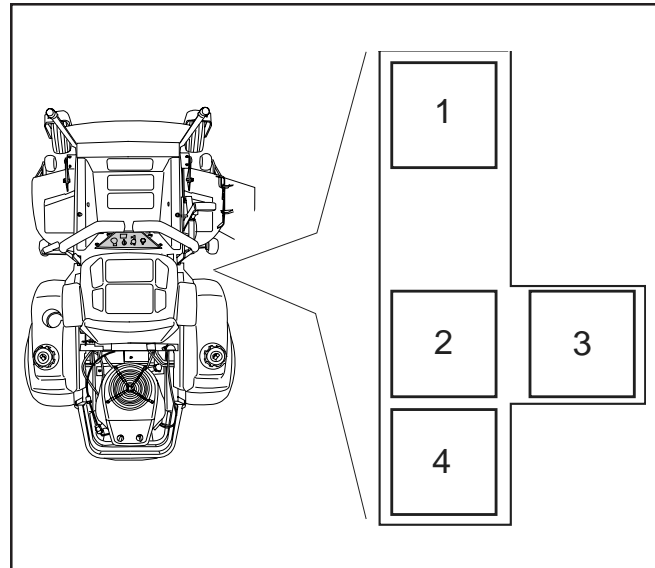

8011-791

1. Forward
2. Neutral
3. Neutral slot, Neutral lock
4. Reverse

Motion control lever pattern (right side)

CONTROLS

2. Seat adjustment lever

The seat can be adjusted lengthways. When making adjustments, sit on the seat. Slide the lever to the side and maneuver seat to appropriate placement and release lever.

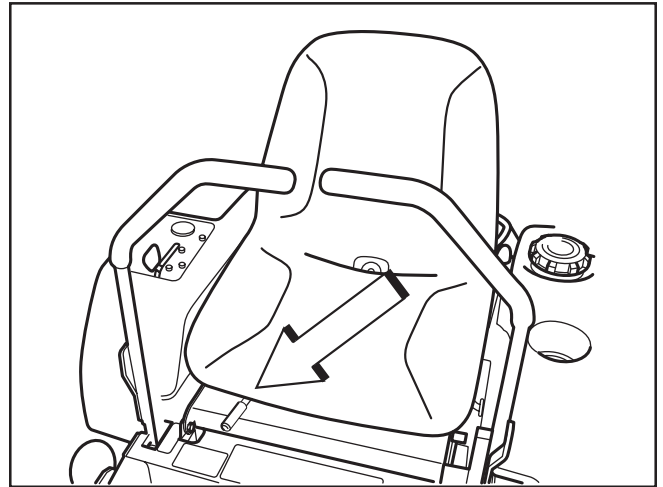

8050-165

Seat adjustment

3. Bypass Linkages

When pushing or pulling the mower, be sure to engage the IZT (Integrated Zeroturn Transaxle) bypass linkages.

- Always turn off engine before engaging or disengaging the hydro release. Never attempt to adjust the bypass linkages with the engine running.
- The hydro release valves are located below the seat, on the front side of the hydro pumps.
- Raise the deck into the highest cutting position.
- Lift the seat frame assembly to access the release valves.
- Use a $\frac{5}{8}$ " wrench to rotate bolt counter-clockwise two full turns to disengage pump.
- Repeat the procedure for the opposite pump.
- To engage, rotate each pump bolt clockwise until the bolt is snug. Do not overtighten the release valve or damage to the hydro pump could occur.

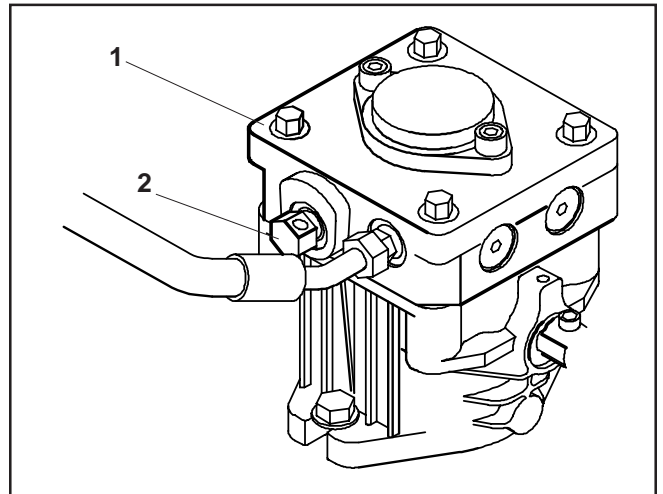

8050-767

1. Left hydro gear
2. Release valve
Bypass linkages

IMPORTANT INFORMATION

Before pushing or towing tractor, transmission must be unlocked and park brake released. The tractor should never be pulled at more than 2 miles per hour (3.2 km/h) or for distances over $\frac{1}{4}$ mile (.402 km). Trailer the unit for distances over $\frac{1}{4}$ mile.

CONTROLS

4. Refueling

The machine has one fuel tank, just behind the seat. The tank capacity is 4.5 gallons (17 liters).

The engine will run on a minimum of 85-octane unleaded gasoline (no oil mix). Environmentally adapted alkylate gasoline can be used. See also Technical Data concerning ethanol fuel. Methanol fuel is not allowed.

When operating below 32°F (0°C) use fresh, clean winter grade gasoline to help insure good cold weather starting.

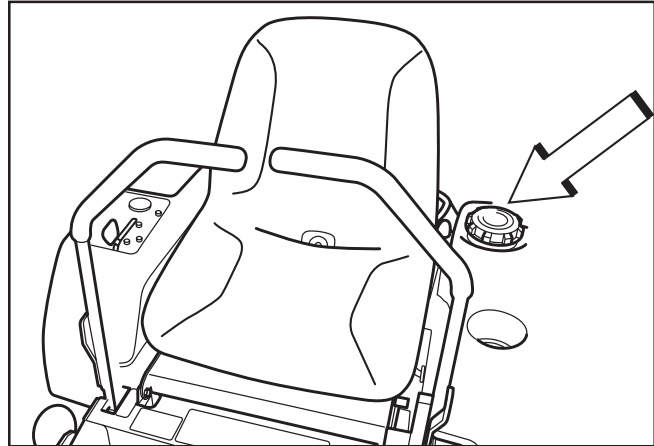

Fuel tank

8050-768



WARNING!

Gasoline is highly flammable. Observe caution and fill the tank outdoors. (See Safety)



WARNING!

Fill to the bottom of the filler neck. Do not overfill. Wipe off any spilled oil or fuel. Do not store, spill or use gasoline near an open flame.



WARNING!

The engine and the exhaust system, become very hot during operation.

Risk for burns if touched.

Allow engine and exhaust system to cool at least two (2) minutes before refueling.

IMPORTANT INFORMATION

Experience indicates that alcohol blended fuels (called gasohol, ethanol or methanol) can attract moisture which leads to separation and formation of acids during storage. Acidic gas can damage the fuel system of an engine while in storage. To avoid engine problems, the fuel system should be emptied before storage of 30 days or longer. Drain the gas tank, start the engine and let it run until the fuel lines and carburetor are empty. Use fresh fuel the next season. See Storage Instructions for additional information. Never use engine or carburetor cleaners in the fuel tank or permanent damage may occur.

CONTROLS

5. Hour Meter

The hour meter displays the total operating time. It will flash CHG OIL (Change Oil) at 50 hour intervals. The flash duration is one hour before and one hour after the interval. The CHG OIL icon will come on and shut off automatically. The hour meter cannot be manually reset.

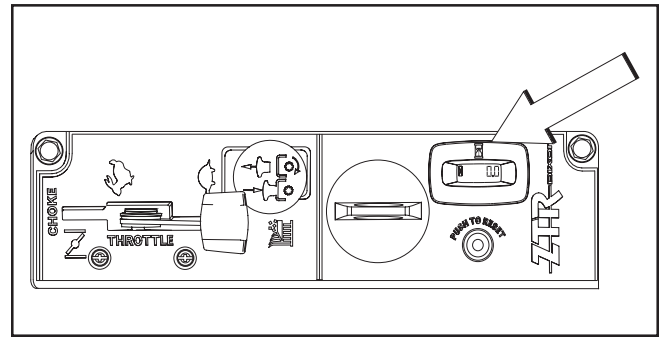

Hour meter

8050-769

6. Ignition Switch

The ignition key is placed on the driver's panel and is used to start and stop the engine.

IMPORTANT INFORMATION

Do not run the starter for more than five seconds each time. If the engine does not start, wait about 10 seconds before retrying.

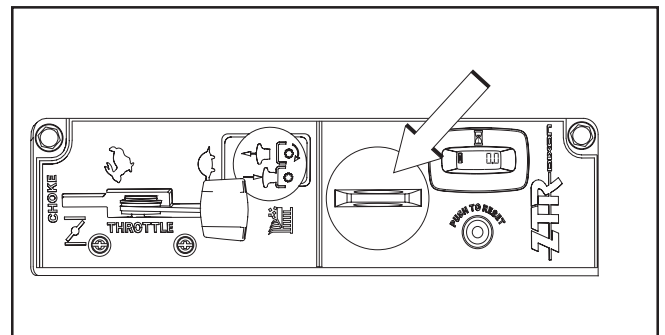

Ignition switch

8050-770

7. Choke Control

The choke mode is used for cold starts in order to provide the engine with a richer fuel mixture. Pressing the throttle control all of the way forward will choke the engine.

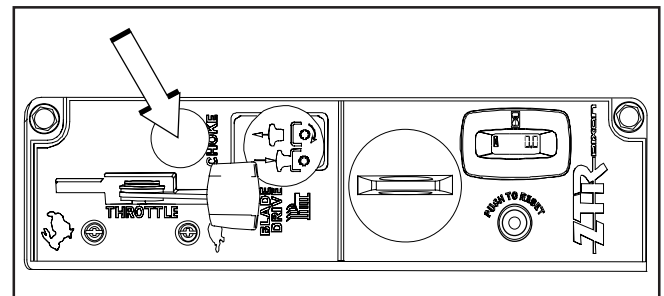

Choke control

8050-771-1

8. Throttle Control

The throttle control regulates the engine speed and thereby the rate of rotation of the blades, assuming the blade switch is pulled out, see Engaging the Mower Deck.

In order to increase or decrease the engine speed, the control is moved.

Avoid idling the engine for long periods, as there is a risk of fouling the spark plug.

USE FULL THROTTLE WHEN MOWING, for best mower performance and battery charging.

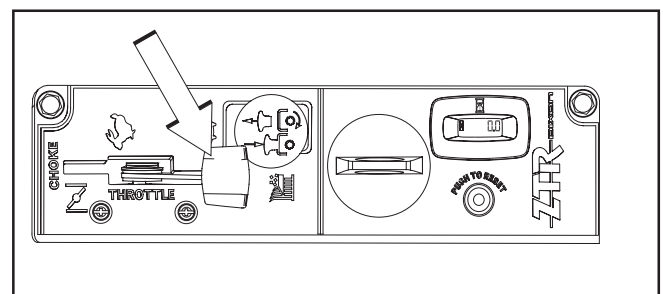

Throttle control

8050-771

CONTROLS

9. Blade switch

In order to engage the mower deck, pull the knob out; the mower blades are disengaged when the knob is depressed.

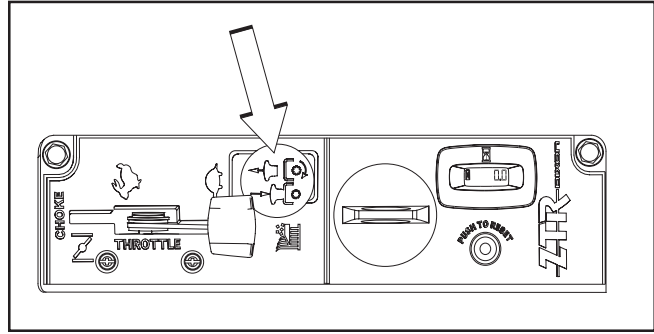

Blade switch

8050-772

10. Circuit breaker

The circuit breaker provides protection for the electrical system by (1) 15 amp circuit breaker. If the circuit breaker trips, push the button to reset. If the condition repeats, consult a dealer for inspection and repair.

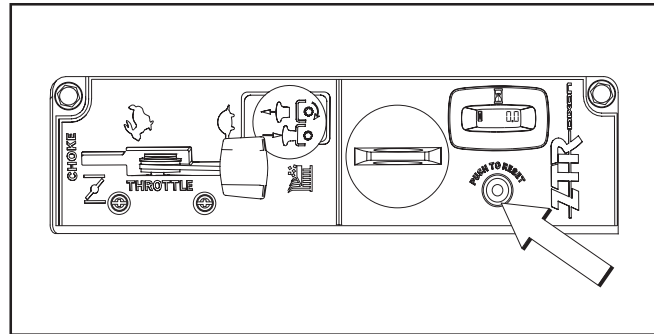

Circuit breaker

8050-775

11. Parking Brake

The parking brake is found on the operator's left. Pull the lever upward to activate the brake and downward to release it.

The park brake is designed to hold the mower from moving and is not intended for use in stopping the mower while it is in motion. The engine will stop if the park brake is engaged while the control levers are in the drive position.

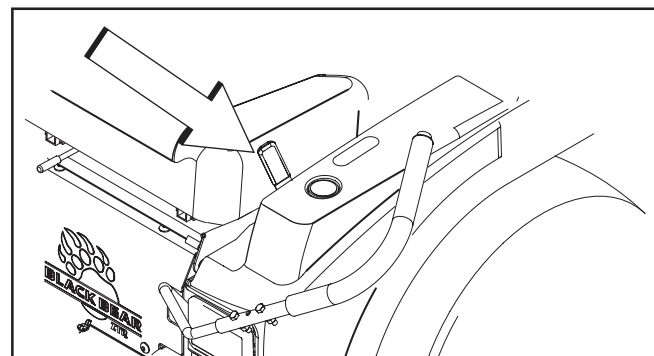

Parking brake activated

8050-773

IMPORTANT INFORMATION

The machine must stand absolutely still when applying the parking brake. Always set the parking brake before dismounting. Release the parking brake before moving the mower.

CONTROLS

12. Mower Deck Cut Height Lift Lever

Located to the right and front of the operator, the lift lever controls the cutting height. The deck cutting height is obtained by pressing the foot pedal forward to lift the deck. To lower the deck, apply pressure to the top side of the foot pedal and allow it to pivot while depressing the trigger and moving the lever forward. Set the desired cut height with pin.

The cutting height range is from 1½" (38 mm) to 5½" (140 mm) in ½" (13 mm) increments. The heights are measured from the ground up to the blade tip with the engine not running.

IMPORTANT INFORMATION

Always use the high position to transport.

IMPORTANT INFORMATION

In order to obtain an even cutting height it is important that the air pressure in all four tires is the same 15 psi (1 bar).

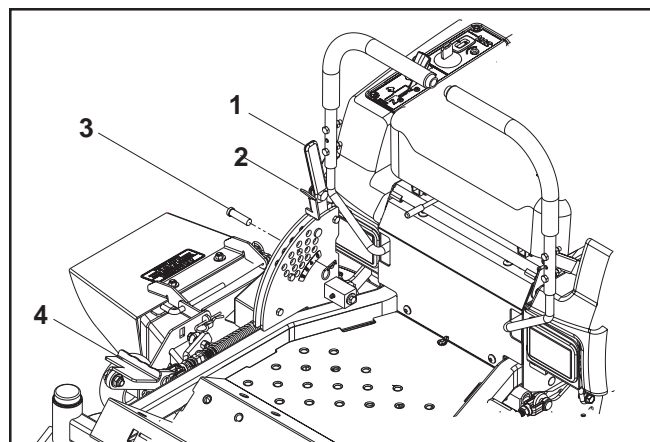

8050-774

1. Lift lever
2. Trigger
3. Set pin
4. Foot pedal

Cut height lift lever and pedal

OPERATION

Operation

Read “Safety Instructions” section and following pages, if you are unfamiliar with the machine.

Training

Zero turn mowers are far more maneuverable than typical riding mowers due to their unique steering capabilities. We suggest that this section be reviewed in its entirety prior to attempting to move the mower under its own power. Additionally, we suggest when first operating the mower, use a reduced throttle speed and reduced ground speed by NOT moving control levers to the furthest forward or reverse positions during initial operation, or until operator becomes comfortable with controls. We also suggest first time users, or new users to Zero Turn mowers to become familiar with the mower’s movement on a hard surface, such as concrete or blacktop PRIOR to attempting to operate on turf. Until operator becomes comfortable with mower controls and zero turning capability, they may damage turf due to overly aggressive maneuvers.

To move forward and backward

The direction and speed of the mower’s movements is effected by the movement of the control lever(s) on each side of mower. The left control lever controls the left wheel. The right control lever controls the right wheel.

IMPORTANT INFORMATION

When control levers are in the reverse position they return to neutral when released. This may cause the mower to suddenly stop.

First time users should push mower (see “Moving by Hand” in the “Operation” section) to an open, flat area, without other people or vehicles/obstacles nearby. In order to move unit under its own power, the operator must be in the seat, start engine (see “Before Starting” in “Operation” section), adjust engine speed to idle, disengage parking brake, do not engage blades at this time, rotate control levers inward. As long as the control levers have not been moved forward or backwards, mower will not move. Slowly move both control levers forward slightly. This will allow mower to start moving forward in a straight line. Pull back on control levers to the neutral position and mower should stop moving. Pull back slightly on control levers, this will allow mower to start moving backwards. Push forward on control levers to the neutral position and mower should stop moving.

To turn to the right

While moving in a forward direction, pull the right lever back towards the neutral position while maintaining the position of the left lever, this will slow the rotation of the right wheel and cause the machine to turn in that direction.

To turn to the left

While moving in a forward direction pull the left lever back towards the neutral position while maintaining the position of the right lever, this will slow the rotation of the left wheel and cause the machine to turn in that direction.

To zero turn

While moving in a forward direction, first pull both control levers back until the mower stops or slows dramatically. Then by alternating one lever slightly to the forward position and the other in the reverse position.

OPERATION

Before Starting

- Read the sections Safety Instructions and Controls before starting the machine.
- Perform the daily maintenance before starting (see Maintenance Schedule in the Maintenance section).
- Check that there is sufficient fuel in the fuel tank.
- Adjust the seat to the desired position.

The following conditions must be fulfilled before the engine can be started:

- The driver must be seated on the seat.
- The blade switch for engaging the mower blades must be depressed.
- The parking brake must be on.
- Both steering controls must be in the locked (outer) neutral position.

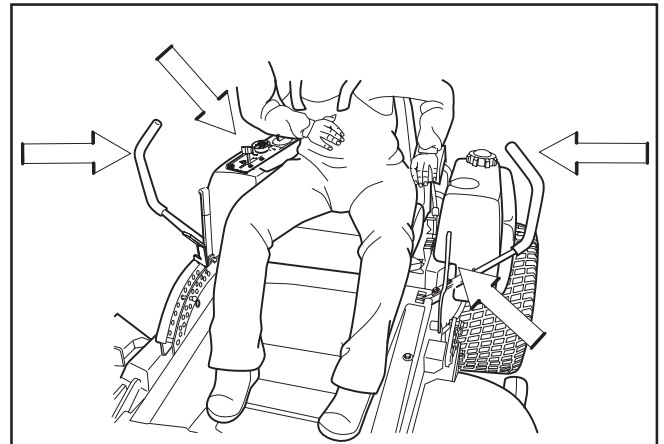

8050-776

Start conditions

Starting the Engine

- Sit on the seat.
- Raise the mower deck by pulling the lifting lever backward to the locked position (transport position).
- Activate the parking brake.

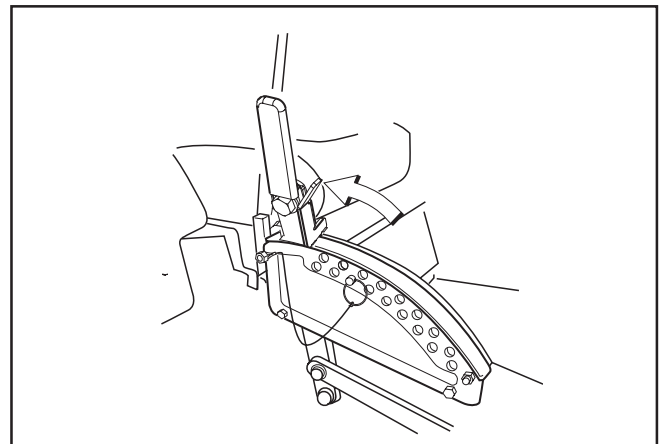

8050-779

Raise the mower deck

- Disengage the mower blades by depressing the blade switch.

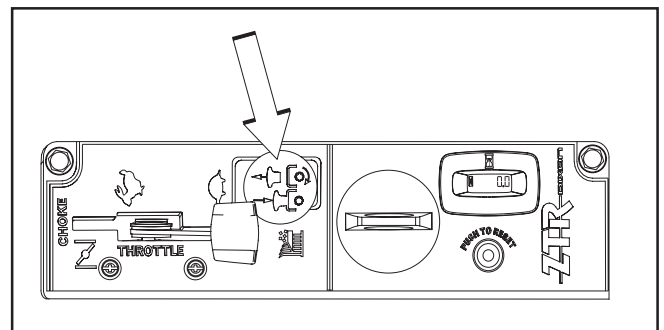

8050-772

Depress the control for disengaging the mower deck

OPERATION

- Move the steering controls outward to the locked (outer) neutral position.

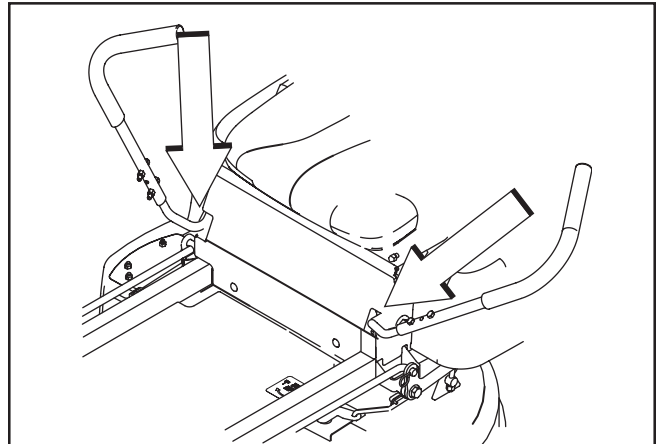

8050-777

Steering controls in the outward, locked neutral position

- Move the throttle to the middle position.
- If the engine is cold, the throttle control should be pushed forward to its choke position.

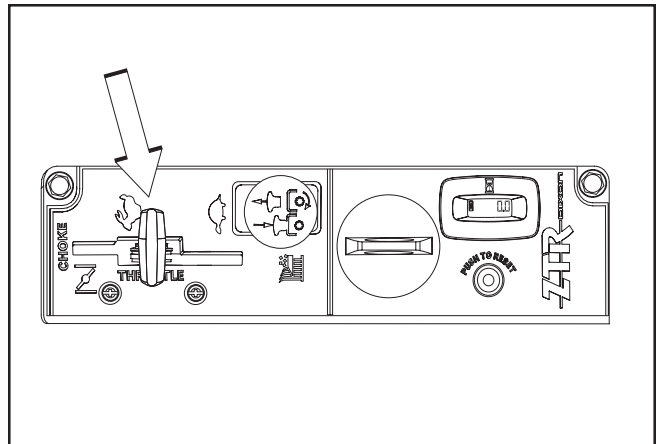

8050-778

Set the throttle

- Press in and turn the ignition key to the start position.

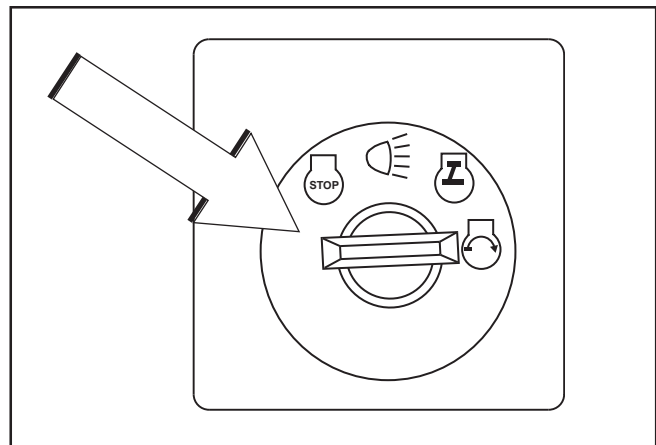

8050-780

Turn to the start position

OPERATION

- When the engine starts, immediately release the ignition key back to the run position.

IMPORTANT INFORMATION

Do not run the starter for more than 5 seconds each time. If the engine does not start, wait about 10 seconds before retrying.

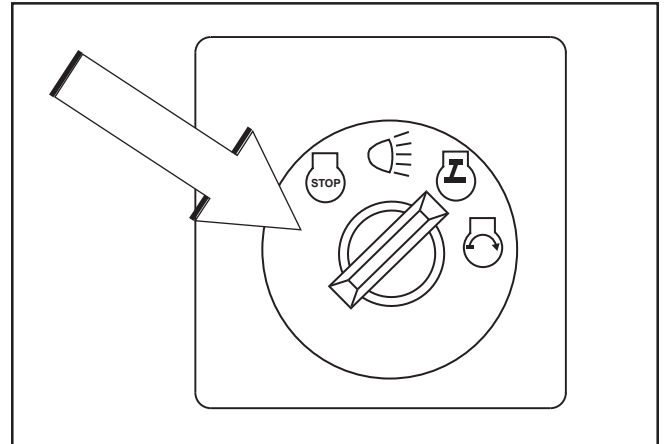

8050-781

Return to run position

- Set the desired engine speed with the throttle.
- Allow the engine to run at a moderate speed, "half throttle", for 3-5 minutes before loading it too heavily.
- USE FULL THROTTLE WHEN MOWING (no choke).

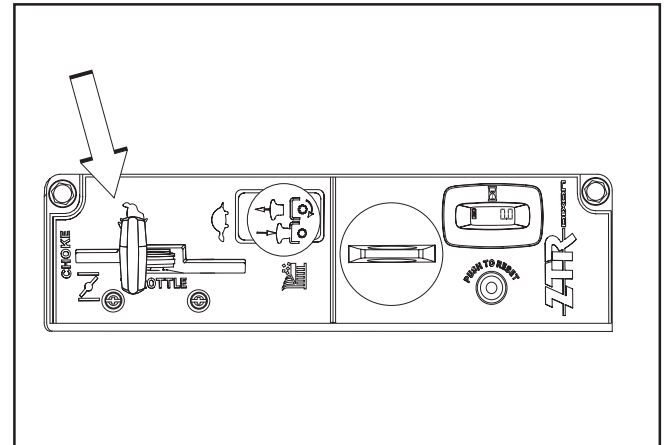

8050-781

Set the engine speed



WARNING!

Engine exhaust and certain vehicle components contain or emit chemicals considered to cause cancer, birth defects or other reproductive system damage. The engine exhaust contains carbon monoxide, which is an odorless, colorless, poisonous gas. Do not use the machine in enclosed spaces.

OPERATION

To start an engine with a weak battery



WARNING!

Lead-acid batteries generate explosive gases. Keep sparks, flame and smoking materials away from batteries. Always wear eye protection then around batteries.

If your battery is too weak to start the engine, it should be recharged. (See "Battery" in the Maintenance Section.)

IMPORTANT INFORMATION

Your mower is equipped with a 12-volt negative grounded system. The other vehicle must also be a 12-volt negative grounded system. Do not use your mower to start other vehicles.

If "jumper cables" are used for emergency starting, follow this procedure:

To attach jumper cables

- Connect each end of the RED cable to the POSITIVE (+) terminal on each battery, taking care not to short against chassis.
- Connect one end of the BLACK cable to the NEGATIVE (-) terminal of the fully charged battery.
- Connect the other end of the BLACK cable to a good CHASSIS GROUND on the mower with the discharged battery, away from the fuel tank and battery.

To remove cables, reverse order

- Remove BLACK cable first from chassis and then from the fully charged battery.
- Remove RED cable last from both batteries.

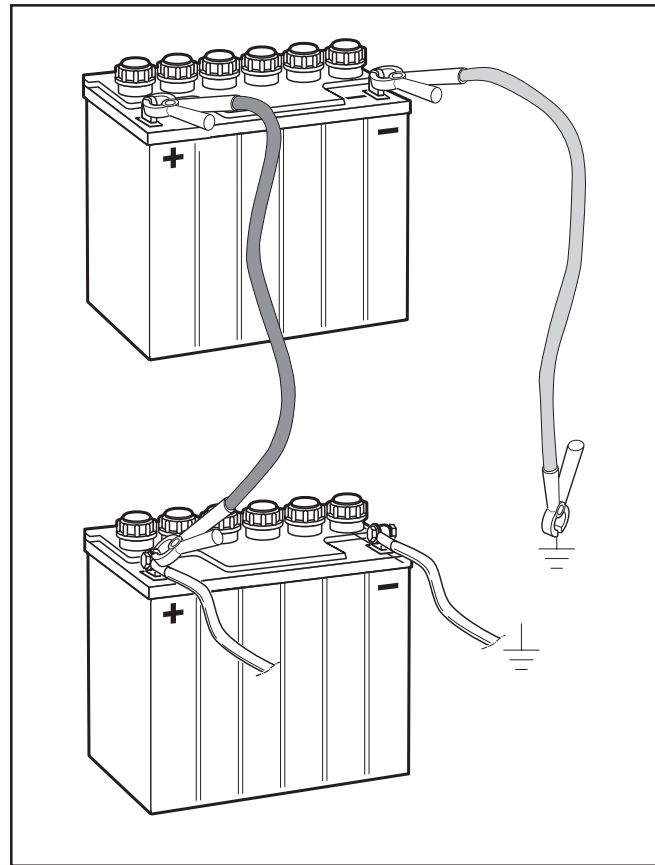

Jumper cable connection

8011-642

OPERATION

Running

1. Release the parking brake by moving the lever downward.
Your mower is equipped with an operator presence system. When the engine is running, any attempt by the operator to leave the seat without first setting the parking brake will shut off the engine.
2. Move the steering controls to the neutral position (N).

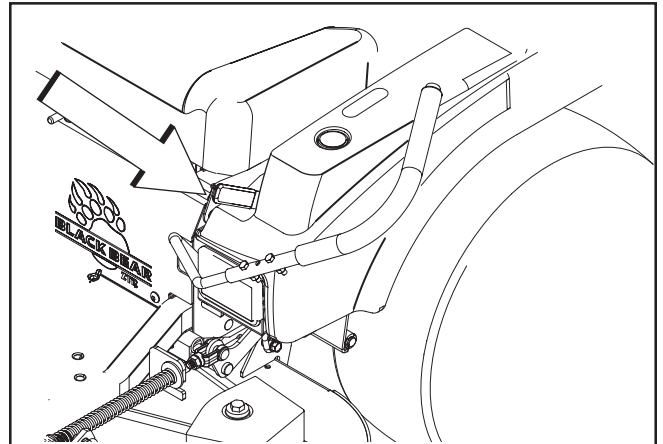

Released parking brake

3. Select the cutting height by the cutting height pedal.

IMPORTANT INFORMATION

The mower deck's anti-scalp rollers should be evenly adjusted.



WARNING!

Ensure that no one is near mower when engaging blade switch.

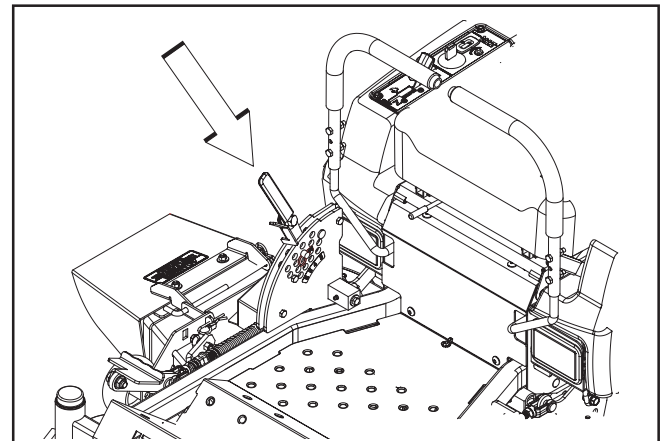

Cut height selection

4. Engage the mower deck by pulling out the blade switch.
5. Move throttle control to full throttle (not choke)
6. The machine's speed and direction are continuously variable using the two steering controls. When both controls are in the neutral position, the machine stands still. By moving both controls an equal amount forward or backward, the machine moves in a straight line forward or backward respectively.

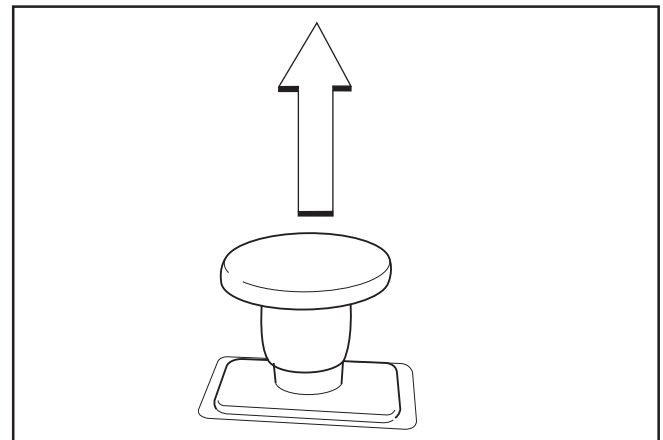

Engaging the mower deck

OPERATION

In order, for example, to turn right while moving forward, move the right control towards the neutral position. The rotation of the right wheel is reduced and the machine turns to the right.

Turning on the spot can be achieved by moving one control backward (behind the neutral position) and carefully moving the other steering control forward from its neutral position.

Operating on hills

Read the Safety Instructions "Driving on Slopes" in the "Safety Instructions".



WARNING!

**Do not drive up or down hills with slopes greater than 10 degrees.
Do not drive across slopes.**

- The slowest speed possible should be used before starting up or down hills.
- Avoid stopping or changing speed on hills.
- If stopping is absolutely necessary, pull drive levers into the neutral position and push to the outside of the unit and engage the parking brake.

IMPORTANT INFORMATION

Control levers return to neutral when released. This may cause the mower to suddenly stop.

- To restart movement, release the parking brake.
- Pull the control levers back to the center of the mower and press forward to regain forward motion.
- Make all turns slowly.

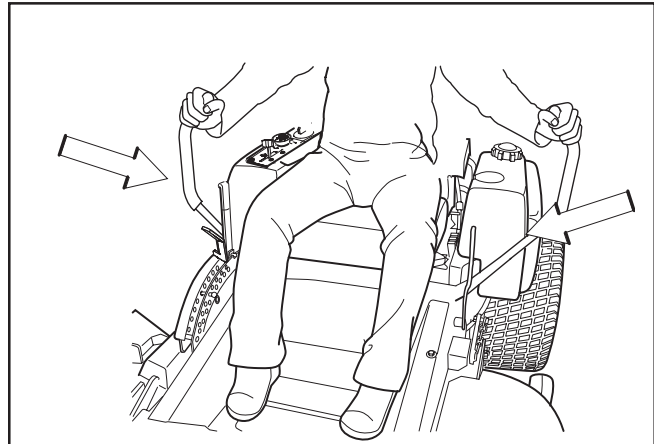

8050-801

Stopping conditions

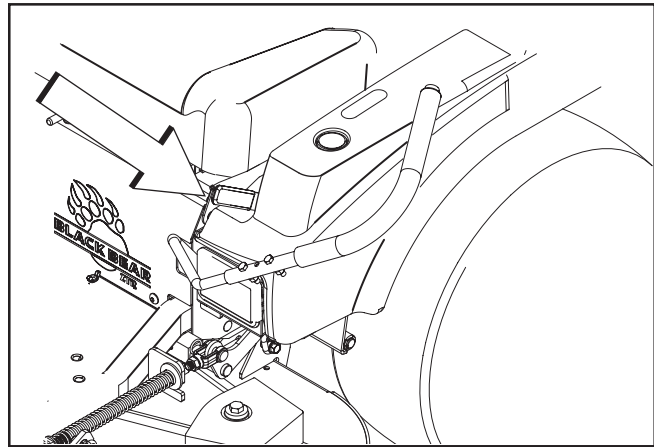

8050-783

Released parking brake

OPERATION

Mowing Tips

- Observe and flag rocks and other fixed objects to avoid collisions.
- Begin with a high cutting height and reduce it until the desired mowing result is attained. The average lawn should be cut to 2½" (64 mm) during the cool season and over 3" (76 mm) during the hot months. For healthier and better looking lawns, mow often after moderate growth.
For best cutting performance, grass over 6" (15 cm) in height should be mowed twice. Make the first cut relatively high; the second to the desired height.
- The mowing result will be best with a high engine speed (the blades rotate rapidly) and low speed (the rider moves slowly). If the grass is not too long and dense, the driving speed can be increased without negatively affecting the mowing result.
- The finest lawns are obtained by mowing often. The lawn becomes more even and the grass clippings more evenly distributed over the mown area. The total time taken is not increased as a higher operating speed can be used without poor mowing results.
- Avoid mowing wet lawns. The mowing result is poorer because the wheels sink into the soft lawn, clumps build, and the grass clippings fasten under the cowling.
- Hose the mower deck underside with water after each use. When cleaning, the mower deck shall be raised into the transport position. Make sure the mower is cooled and the engine is off.
- Use compressed air to clean top surface of the deck. Avoid flooding water on top surface, engine and electrical components.
- When the mulching kit is used, it is important that the mowing interval is frequent.



WARNING!

Clear the lawn of stones and other objects that can be thrown out by the blades.

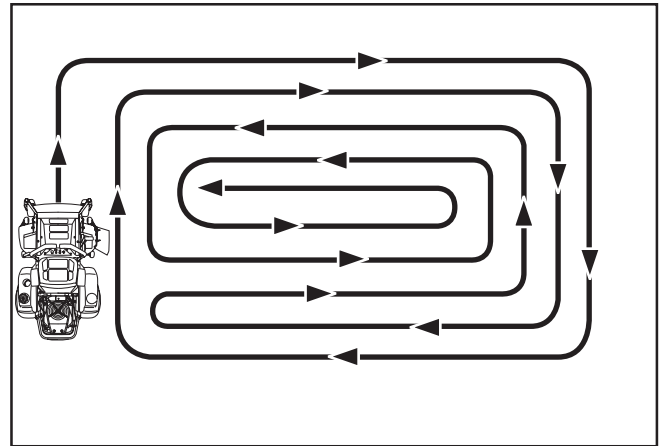

8011-603

Mowing pattern



WARNING!

Never drive the rider on terrain that slopes more than 10 degrees. Mow slopes up and down, never side to side. Avoid sudden directional changes.

OPERATION

Stopping the Engine

Allow the engine to idle a minute in order to attain normal operating temperature before stopping it, if it has been worked hard. Avoid idling the engine for longer periods, as there is a risk of the spark plugs fouling.

- Disengage the mower deck by depressing the blade switch.

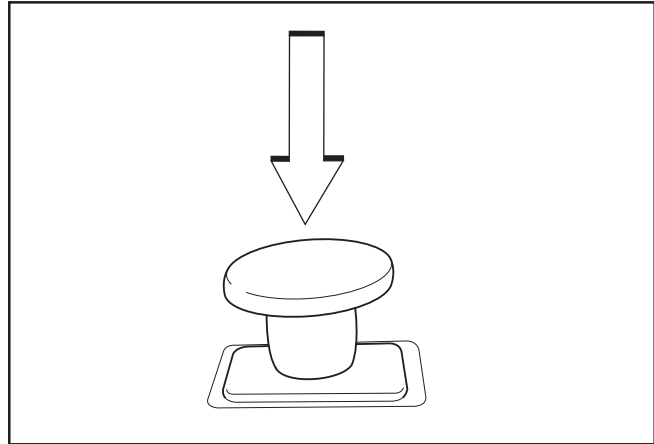

8011-668

Disengage the mower deck

- Raise the mower deck by depressing the pedal forward to the transport position.
- When the machine is standing still, activate the parking brake by pulling the lever upward.
- Move the throttle to the minimum position (tortoise symbol). Turn the ignition key to the stop position.
- Move the steering controls outward.
- Remove key. Always remove key when leaving the mower to prevent unauthorized use.

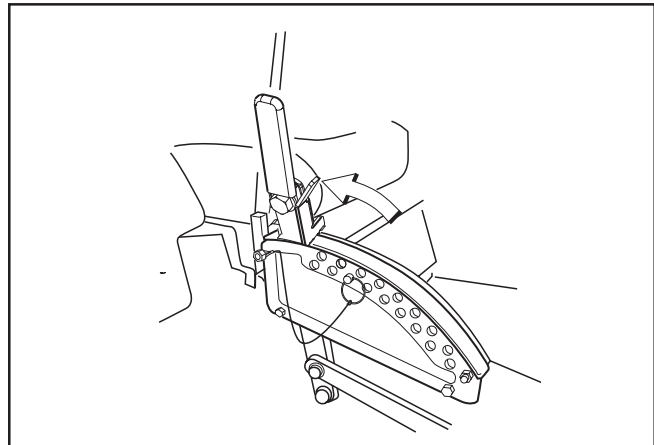

8050-779

Raise the mower deck

IMPORTANT INFORMATION

Leaving the ignition switch in any other position than “OFF” will cause the battery to be discharged.

OPERATION

Moving by Hand



WARNING!

Make no adjustments without:

- ◆ the engine stopped
- ◆ the ignition key removed
- ◆ the parking brake activated

When pushing or pulling the mower, be sure to engage the IZT (Integrated Zereturn Transaxle) bypass linkages.

- Always turn off engine before engaging or disengaging the hydro release. Never attempt to adjust the bypass linkages with the engine running.
- The hydro release valves are located below the seat, on the front side of the hydro pumps.
- Raise the deck into the highest cutting position.
- Lift the seat frame assembly to access the release valves.
- Use a $\frac{5}{8}$ " wrench to rotate bolt counter-clockwise two full turns to disengage pump.
- Repeat the procedure for the opposite pump.
- To engage, rotate each pump bolt clockwise until the bolt is snug. Do not overtighten the release valve or damage to the hydro pump could occur.

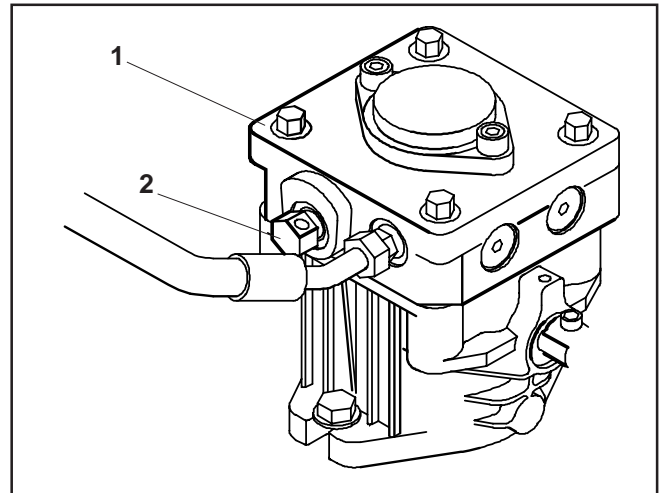

8050-767

1. Left hydro gear
2. Release valve
Bypass linkages

MAINTENANCE

Maintenance Schedule

The following is a list of maintenance procedures that must be performed on the machine. For those points not described in this manual, visit an authorized service workshop. An annual service carried out by an authorized service workshop is recommended to maintain your machine in the best possible condition and to ensure safe operation.

Read "Maintenance" in the Safety Instructions section.

● = Described in this manual

◆ = Not described in this manual

¹⁾ First change after 5-8 hours. When operating with a heavy load or at high ambient temperatures, replace every 50 hours. ²⁾ In dusty conditions, cleaning and replacement are required more often. ³⁾ Performed by authorized service workshop.

Maintenance	Page	Daily		Weekly	At Least Once Each Year	Maintenance Interval In Hours			
		Before	After			25	50	100	300
Check the parking brake		●							
Check the engines oil level (every refueling)		●							
Check the safety system		●							
Check for fuel and oil leakages		◆							
Check/clean the engine's cooling air intake			●						
Check the mower deck			●						
Check hardware (screws, nuts, etc)			●						
Clean under the mower deck			●						
Start the engine and blades, listen for unusual sounds			◆						
Check for damage			◆						
Thoroughly clean around the engine			◆						
Clean around belts, belt pulleys, etc.			◆						
Check the tire pressures						●			
Check battery						●			
Sharpen/replace mower blades						●			
Check the fuel pump's air filter ²⁾						●			
Clean the engine's cooling air intake ²⁾					●	●			
Clean the air cleaner's pre filter ²⁾ (foam)					●	●			
Clean the air cleaner's filter cartridge ²⁾ (paper filter)					●		●		
Check/adjust the parking brake					◆		◆		
Inspect muffler/spark arrester					◆		◆		

MAINTENANCE

Maintenance	Page	Daily		Weekly	At Least Once Each Year	Maintenance Interval In Hours			
		Before	After			25	50	100	300
Check/adjust throttle cable								●	
Check the condition of belts, belt pulleys, etc.					●			●	
Change the engine oil ¹⁾					●		●		
Replace the engine oil filter					●			●	
Clean/replace the spark plugs					●			●	
Replace the air filter (paper filter) ²⁾					●			●	
Check the caster wheels (every 200 hours)								●	
Clean the cooling fins ²⁾					◆			◆	
Replace the air cleaner's pre-filter ²⁾ (foam)					●				●
Check/adjust the mower deck					●				●
Check the engine valve clearance ³⁾					◆				◆
Perform the 300-hour service ³⁾					◆				◆

¹⁾ First change after 5-8 hours. When operating with a heavy load or at high ambient temperatures, replace every 50 hours. ²⁾ In dusty conditions, cleaning and replacement are required more often. ³⁾ Performed by authorized service workshop.

● = Described in this manual

◆ = Not described in this manual



WARNING!

No adjustments or maintenance to be carried out unless:

- The engine is stopped.
- The ignition key has been removed.
- The parking brake is on.

MAINTENANCE

Battery

Your mower is equipped with a maintenance free battery and does not need servicing. However, periodic charging of the battery with an automotive type battery charger will extend its life.

- Keep battery and terminals clean.
- Keep battery bolts tight.
- Recharge at 6-10 amperes for 1 hour

To clean battery and terminals

Corrosion and dirt on the battery and terminals can cause the battery to “leak” power.

1. Lift seat and rotate forward.
2. Disconnect BLACK battery cable first, then the RED battery cable and remove the battery from the machine.
3. Rinse the battery with plain water and dry.
4. Clean terminals and battery cable ends with wire brush until shiny.
5. Coat terminals with grease or petroleum jelly
6. Reinstall battery.

Replacing battery

1. Lift seat and rotate forward.
2. Open terminal access doors.
3. Using two ½" wrenches disconnect BLACK battery cable then RED battery cable.
4. Position deck to lowest setting.
5. Front underside of frame, remove the nuts that secure the battery hold-down.
6. Carefully remove the battery from the mower.
7. Install new battery with terminals in the same position as the old battery.
9. Reinstall battery hold-down and secure with nuts removed in Step 5.
9. First connect RED battery cable to positive (+) battery terminal with hex bolt and hex nut.
10. Connect BLACK grounding cable to negative (-) battery terminal with remaining hex bolt and hex nut.
11. Tighten securely.
12. Lower seat

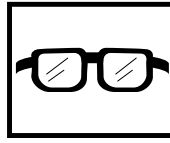

Always use protective glasses when handling the battery.

IMPORTANT INFORMATION!

Do not attempt to open or remove caps or covers. Adding or checking level of electrolyte is not necessary.

Always use two wrenches for the terminals screws.



WARNING!

Do not short battery terminals by allowing the wrench to contact both terminals at the same time. Before connecting battery, remove metal bracelets, wristwatch bands, rings, etc. Positive terminal must be connected first to prevent sparks from accidental grounding.

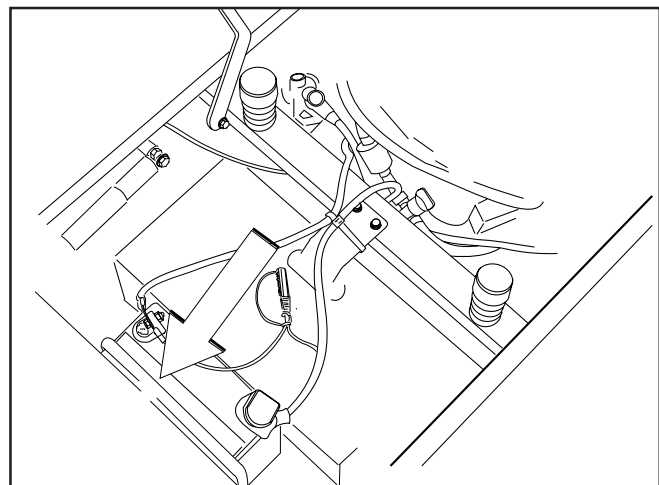

8050-109

Remove battery hold-down to replace battery

MAINTENANCE

Ignition System

The engine is equipped with an electronic ignition system. Only the spark plug requires maintenance. For recommended spark plug, see Technical Data.

1. Remove the ignition cable boot and clean around the spark plug.
2. Remove the spark plug with a spark plug socket wrench.
3. Check the spark plug. Replace the spark plug if fouled, the electrodes are burned and if the insulation is cracked or damaged. Clean the spark plug with a steel brush if it is to be reused.
4. Measure the electrode gap with a gapping tool. The gap should be .030" (0.75 mm). Adjust as necessary by bending the side electrode.
5. Reinsert the spark plug, turning by hand to avoid damaging the threads.
6. After the spark plug is seated, tighten it using a spark plug wrench so that the washer is compressed. A used spark plug should be turned $\frac{1}{8}$ of a turn from the seated position. A new spark plug should be turned $\frac{1}{4}$ turn from the seated position.
7. Replace the ignition cable.

Checking the Safety System

The machine is equipped with a safety system that prevents starting or driving under the following conditions.

The engine can only be started when:

- The mower deck is disengaged.
- The steering controls are in the outer, locked neutral position.
- The driver is sitting in the driver's seat.
- The parking brake is on.

Make daily inspections to ensure that the safety system works by attempting to start the engine when one of the conditions is not met. Change the conditions and try again.

If the machine starts when one of these conditions is not met, turn the machine off and repair the safety system before using the machine again.

1. Make sure the engine stops when the parking brake is not engaged and the operator leaves the seated position.
2. Check that the engine stops if the mower blades are engaged and the driver temporarily stands up.

IMPORTANT INFORMATION

Fitting the wrong spark plug type can damage the engine.

Inadequately tightened spark plug can cause overheating and damage the engine. Tightening the spark plug too hard can damage the threads in the cylinder head.

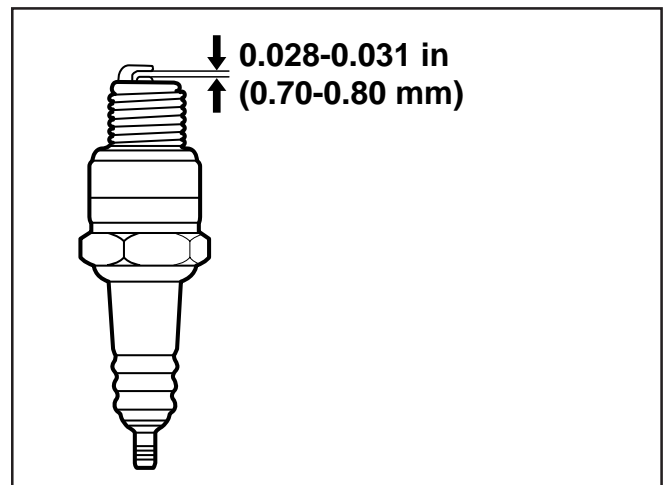

8011-054

Measure the electrode gap

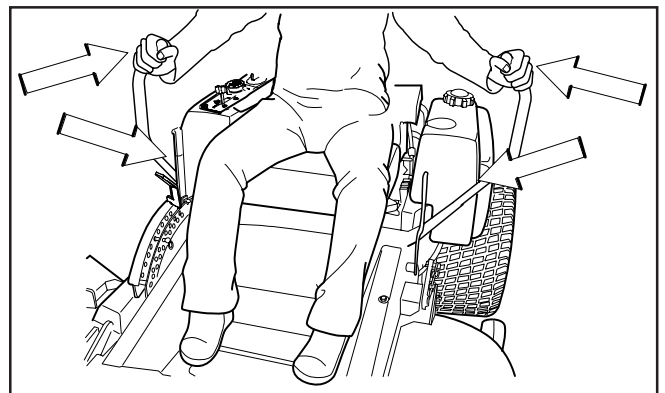

8050-801

Starting conditions

MAINTENANCE

Checking the Engine's Cooling Air Intake

Check that the engine's cooling air intake is free from leaves, grass, and dirt.

If the cooling air intake is clogged, engine cooling deteriorates, which can lead to engine damage.

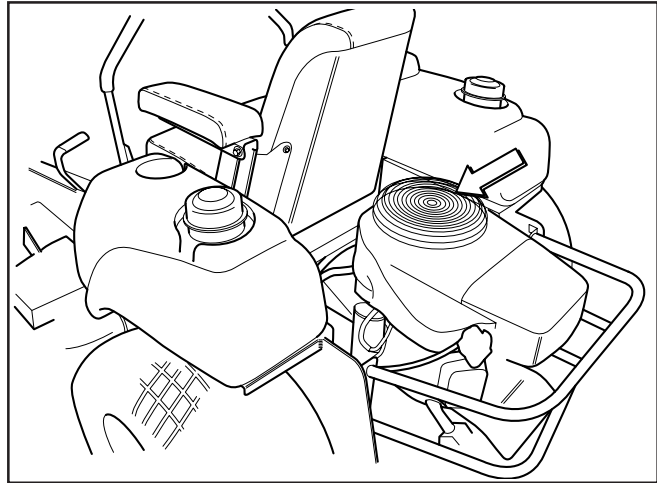

8011-625

Check and clean the cooling air intake

Checking and Adjusting the Throttle Cable

Check that the engine responds to throttle increases and that a good engine speed is attained at full throttle.

If doubts arise, contact the service workshop.

If adjustments are necessary, they can be made as follows for the lower cable:

1. Loosen the clamping screw for the cable's outer casing and move the throttle to the full throttle position.
2. Check that the throttle cable is mounted in the correct hole in the lower lever, see illustration.
3. Push the throttle cable's outer casing as far to the left as possible and tighten the clamping screw.

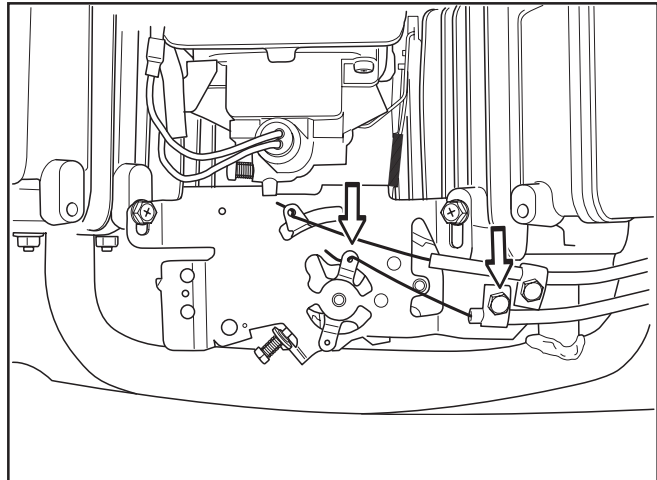

8011-554

Adjusting the throttle cable

Checking and Adjusting the Choke Cable

If the engine produces black smoke or is difficult to start, this may be because the choke cable is incorrectly adjusted (upper cable).

If doubts arise, contact the service workshop.

If adjustments are necessary, they can be made as follows:

1. Loosen the clamping screw for the cable's outer casing and move the choke lever to the full choke position.
2. Check that the choke cable is mounted in the upper lever, see illustration. Push the choke cable's outer casing as far to the right as possible and tighten the clamping screw.

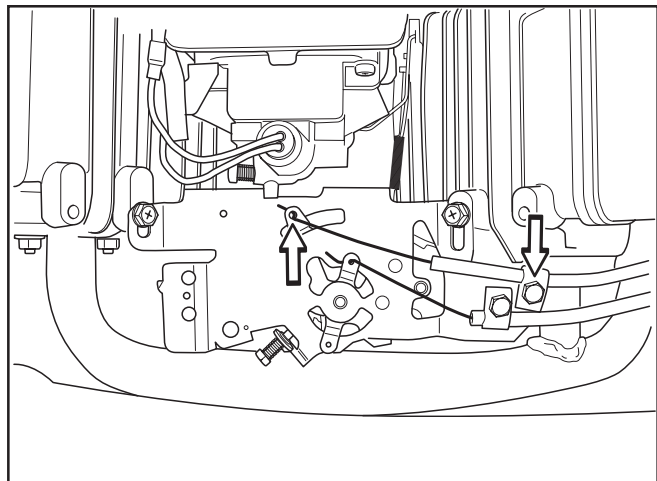

8011-555

Adjusting the choke cable

MAINTENANCE

Replacing the Air Filter

If the engine seems weak or runs unevenly, the air filter may be clogged. If run with a dirty air filter, the spark plugs can become fouled, disrupting operation. For this reason, it is important to replace the air filter regularly (see the heading Maintenance Schedule for the proper service interval).



WARNING!

The engine and the exhaust system become very hot during operation. There is a risk for burns if touched. Allow engine and exhaust system to cool at least two (2) minutes.

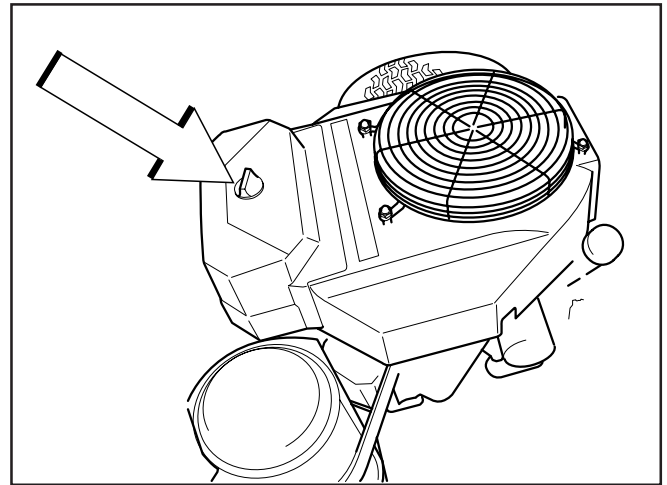

8011-768

Remove the air filter cowling

Cleaning/replacing the air filter is carried out as follows:

1. Remove the plastic fastener on the top of the air filter cowling and remove the air filter cowling.
2. Remove the foam rubber pre-filter and clean using a mild detergent. Squeeze it dry with a clean cloth.

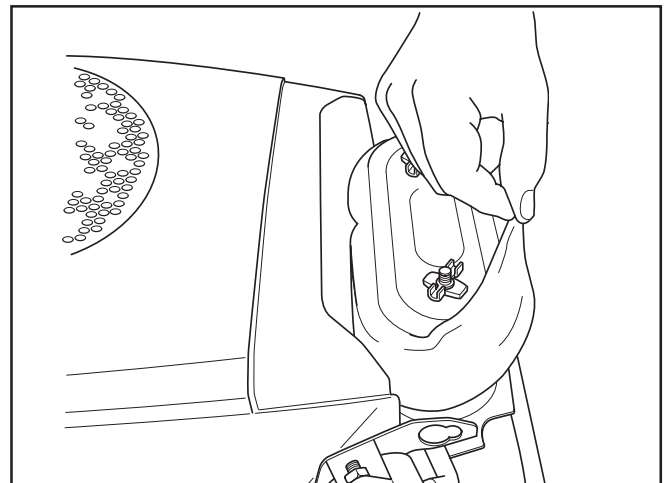

8011-557

Remove pre-filter

3. Remove the wing nuts for the air filter and remove the paper filter.

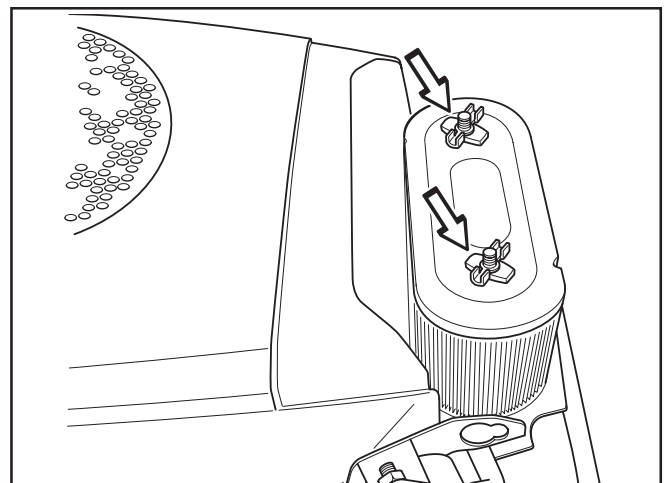

8011-558

Remove paper filter

MAINTENANCE

IMPORTANT INFORMATION!

Do not use compressed air to clean the air filter. Do not wash the paper filter. Do not oil the paper filter.

4. Tap the paper filter against a fixed surface to remove dust. If the paper filter is still dirty, it must be replaced.

Refit the air filter as follows:

1. Check that the seal on the bottom of the paper filter is whole.
2. Mount the paper filter in the air filter housing and tighten the wing nuts.
3. Refit the pre-filter on the paper filter.
4. Replace the cowling over the air filter housing. Do not over tighten the plastic fastener.

Replacing the Fuel Filter

Replace the line-mounted fuel filter every 100 hours (once per season) or more regularly if it is clogged.

Replace the filter as follows:

1. Move the hose clamps away from the filter. Use flat-nosed pliers.
2. Pull the filter loose from the hose ends.
3. Push the new filter into the hose ends. Position the filter with the "FLOW" arrow pointing up toward the carburetor. If necessary, a soap solution can be applied to the filter ends to ease mounting.
4. Move the hose clamps back toward the filter.

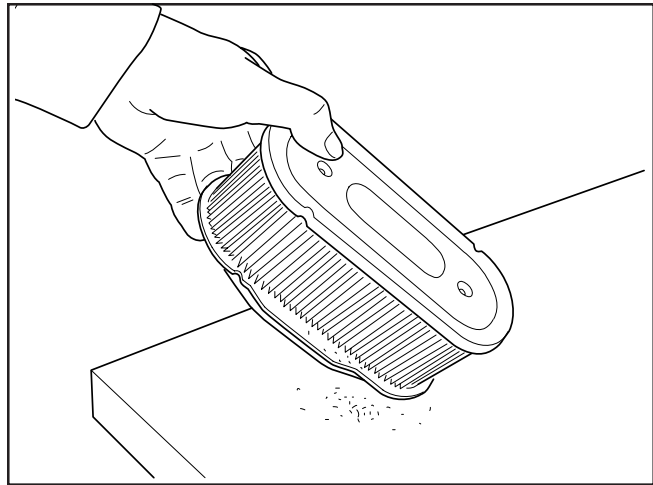

8009-181

Remove dust

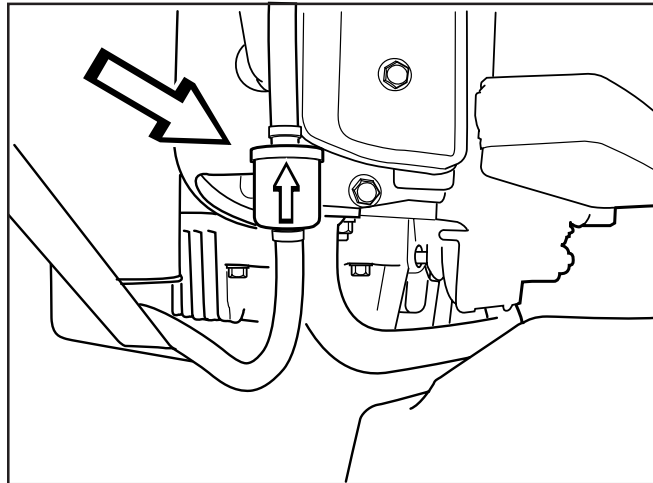

8009-146

Fuel filter

Checking the Fuel Pump's Air Filter

Regularly check that the fuel pump's air filter is free from dirt.

Remove the screws and open the pump, no hoses need be removed.

The filter can be cleaned with a brush if necessary.

Replace the filter on the console.

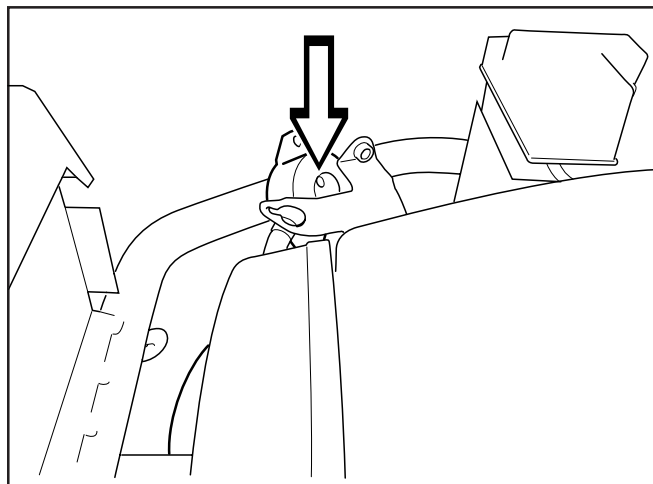

8009-147

Fuel pump air filter

MAINTENANCE

Checking Tire Pressures

All four tires should have a pressure of 15 psi / 103 kPa / 1 bar.

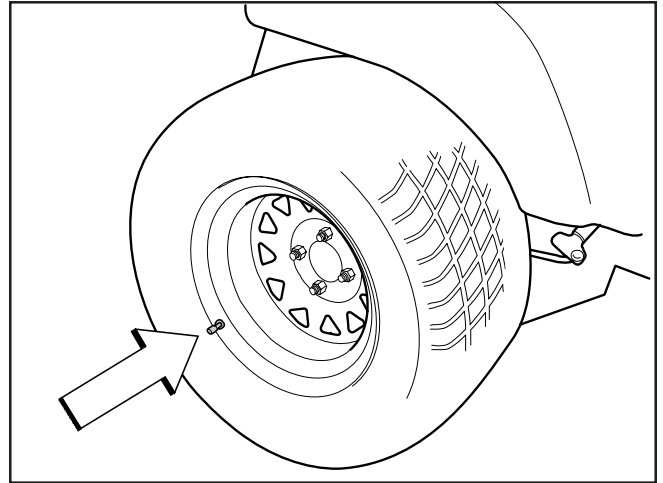

8009-181

Remove dust

Checking the Parking Brake

Visually check that no damage is found on the lever, linages, or switch belonging to the parking brake. Perform a stand still test and check that there is a braking action.

To adjust the parking brake, contact the Dixon service workshop.



WARNING!

Faulty adjustment can cause an accident.



WARNING!

The machine must be standing absolutely still when the park brake is engaged.

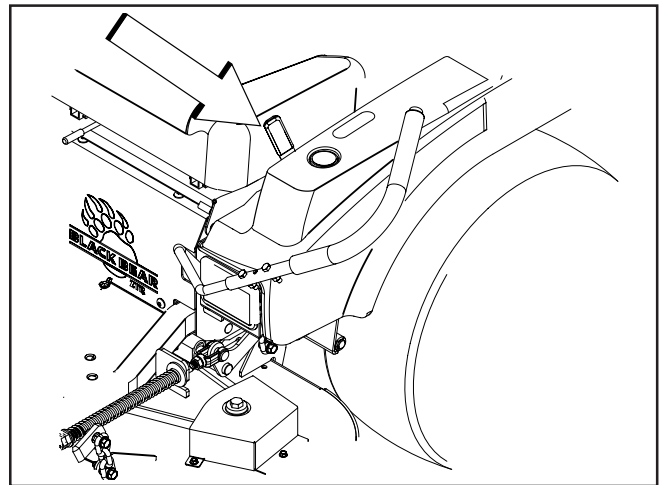

8050-773

Parking brake engaged

Checking the V-belts

Deck belt

Inspect every 50 hours of operation. Check for severe cracking and large nicks.

NOTE: The belt will show some small cracks in normal operation.

Belt tension is manually adjustable. Turn bolt on deck eyebolt to adjustment tension.

NOTE: Belt deflection or movement should be approximately 1/4" (6mm) when measured at midpoint between pulleys. Periodically inspect both belt and idler systems.

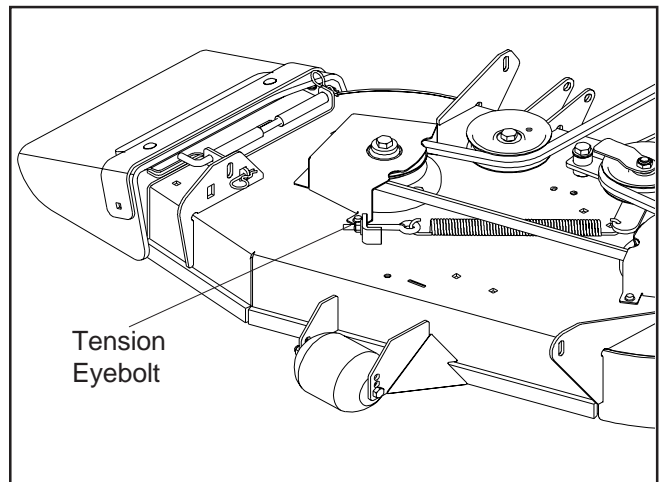

8050-773

Adjusting belt tension

MAINTENANCE

Deck belt removal

1. Park on a level surface. Apply parking brake.
2. Lower the deck into the lowest cutting position.
3. Remove bolts from belt shields and remove shields.
4. Remove any dirt or grass that may have accumulated around the cutter housings and entire deck surface.
5. Carefully roll the belt over the top of the cutter housing pulleys and remove belt.

Deck belt installation

NOTE: For ease in installing the deck belt, refer to the routing decal on bottom of seat.

1. Wrap the deck belt around the electric clutch pulley that is located on the engine shaft.
2. Route the belt forward between the EZT (E-Series Zereturn Transaxles) and up onto the deck.
3. Place belt around spring loaded idler pulley.
4. Wrap the belt around the stationary idler pulley and around the mandrel housings.
5. Push inward on the idler arm and carefully route belt over stationary idler pulley. Once belt is properly routed, slowly release idler arm to tension belt.
6. Double check belt routing to make sure it matches the routing decal, and the belt does not have any twist. Correct as needed.
7. Adjust tension with deck eyebolt.
8. Replace belt shields on both mandrel housings and secure with fasteners.

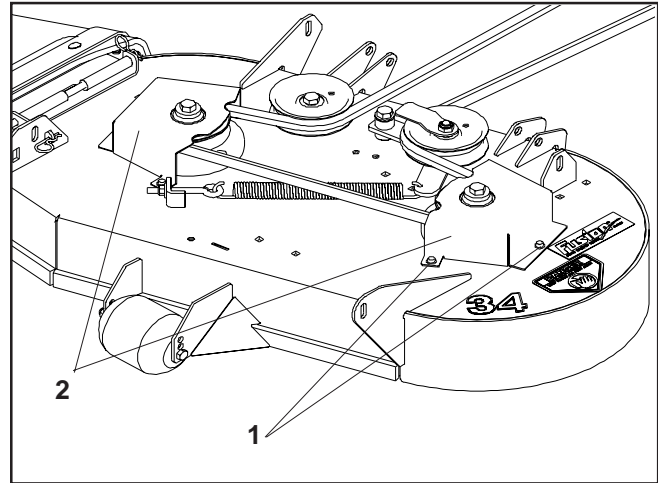

8050-773

1. Shield bolts
 2. Belt shields
- Removing deck belt*

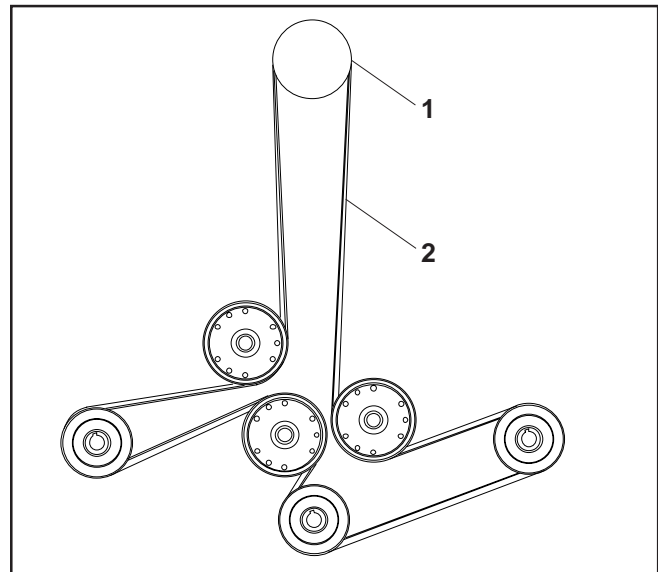

8050-773

1. Clutch pulley
 2. Deck belt
- Belt routing, deck belt*

MAINTENANCE

Pump Belt

To replace EZT (E-Series Zereturn Transaxle) belt

Park the mower on a level surface. Engage the parking brake.

EZT belt removal

NOTE: Be careful not to damage the fan blades on the EZT's as this can affect cooling or damage the EZT's

- Remove the deck belt (see Deck Belt Removal in this section of the manual).
- Create slack in the belt by removing the spring on the pump idler arm.
- The belt should now be able to be removed from the engine pulley and EZT pulleys.

Belt installation

- Wrap the EZT belt around the EZT pulleys
- Route the belt around the inside of the idler pulley.
- Wrap the belt around the engine pulley.
- Reattach the spring on the pump idler arm.
- Install clutch on to engine shaft (pulley side down) make sure key is installed and align the clutch anti rotation tab into slot on clutch. Secure clutch, install wire.
- Reinstall the deck belt onto the electric clutch belt (see Deck Belt Removal in this section of the manual).

Checking the Blades

In order to attain the best mowing effect, it is important that the blades are well sharpened and not damaged.

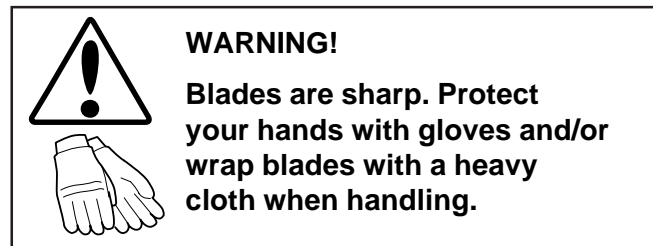

- Bent or cracked blades or blades with large nicks should be replaced.
- Check the blade mounts.

Damaged blades should be replaced when hitting obstacles that result in a breakdown. Let the service workshop decide whether the blade can be repaired/ground or must be replaced.

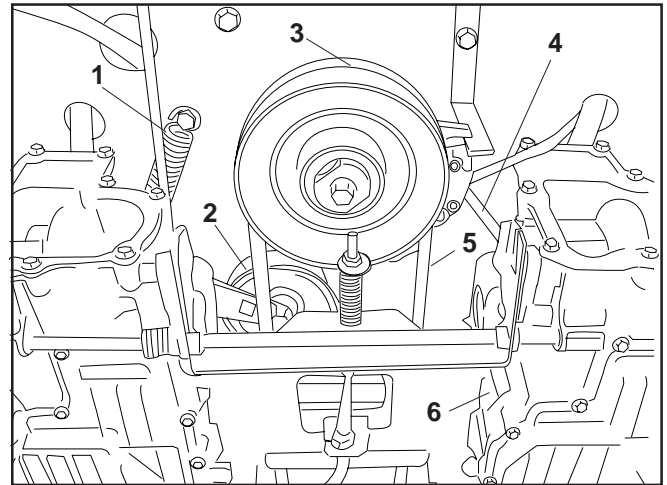

CZ-21

1. Pump idler arm spring
2. Pump idler
3. Electric clutch
4. IZT belt
5. Deck belt
6. IZT support IZT belt

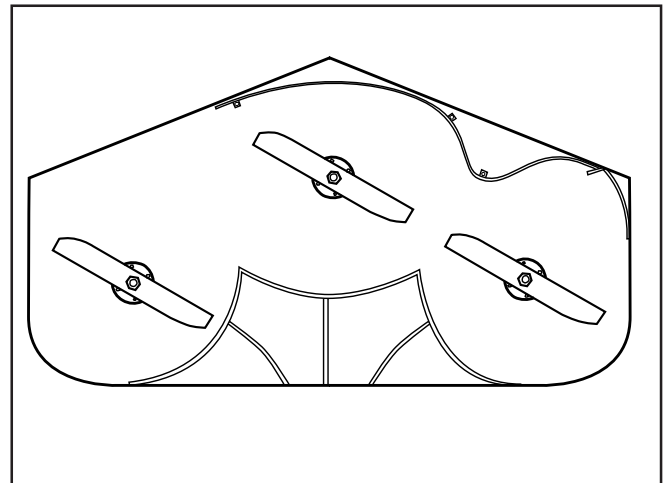

8011-604

Check the blades

IMPORTANT INFORMATION

The sharpening of blades should be carried out by an authorized service workshop.

MAINTENANCE

Blade replacement



WARNING!

Blades are sharp. Protect your hands with gloves and/or wrap blades with a heavy cloth when handling.

- Remove blade bolt by turning counterclockwise.
- Install new or re-sharpened blade with stamped "GRASS SIDE" facing towards ground/grass (down) or "THIS SIDE UP" facing deck and cutter housing.
- Install and tighten blade bolt securely. Torque blade bolt to 27-35 ft/lb (35-45 Nm).

IMPORTANT INFORMATION

Special blade bolt is heat treated.
Replace with a Husqvarna bolt if required.
Do not use lower grade hardware than specified.

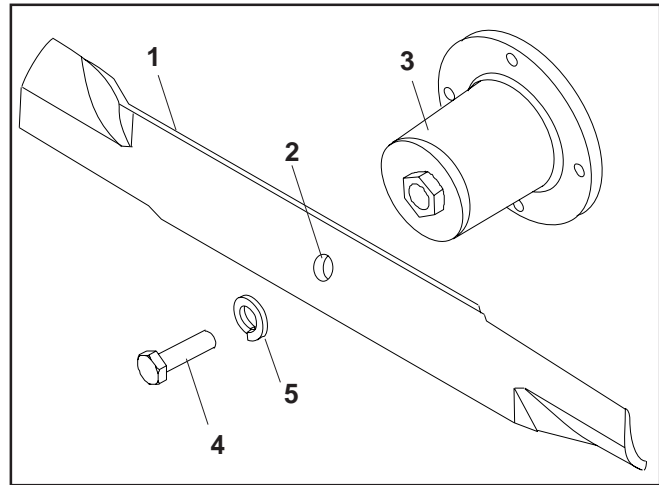

8050-802

1. Blade
2. Center hole
3. Cutter housing
4. Blade bolt
5. Lockwasher

Blade attachment

MAINTENANCE

Adjusting the Mower Deck



WARNING!

Before performing any service or adjustment, check the following list:

1. Engage the parking brake.
2. Place the blade switch in the disengaged position.
3. Turn ignition switch to "OFF" position and remove the key.
4. Make sure the blades and all moving parts have completely stopped.
5. Disconnect the spark plug wire from all spark plugs and place the wire where it cannot come in contact with the plug.

Check the tire pressure before adjustment of the mower deck. See "Checking Tire Pressure" in Maintenance section. Faulty mower deck adjustments will cause an uneven mowing result.



WARNING!

Blades are sharp. Protect your hands with gloves and/or wrap blades with a heavy cloth when handling.



To level deck

Adjust the deck while the mower is on a level surface. Make sure the tires are inflated to the correct pressure. See "Technical Data" under Transmission. If tires are under or over inflated, you cannot properly adjust your deck.

Four slots control the height and pitch of the mower deck. The deck should be adjusted slightly higher in the rear.

NOTE: To insure accuracy of leveling procedure, mower deck drive belt must be installed prior to leveling deck.

1. Wear heavy gloves. Turn each outer blade tip to align with the deck or in a side-to-side manner.
2. Measure from the floor surface up to the bottom of the blade tip on the discharge side of the mower deck.

Retain this measurement. Move to the opposite side, check that measurement is the same. If adjustment is required, loosen the locknut and move mounting bolt up or down in slot until both side-to-side measurements are equal. Retain measurement.

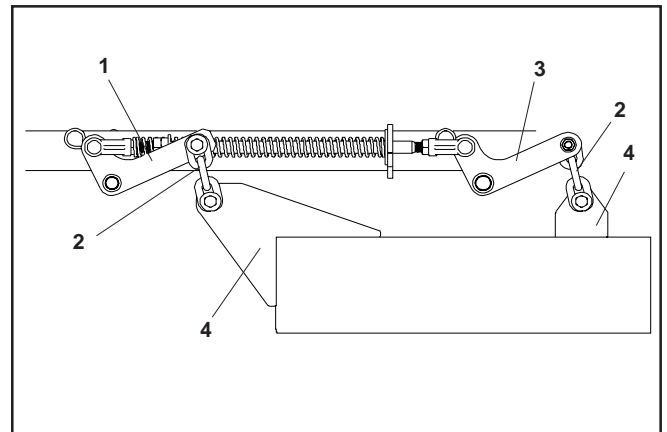

1. Front Lift Arm
2. Chain
3. Rear Lift Arm
4. Slotted Deck Hanger Plates

Leveling mower deck

MAINTENANCE

3. Turn both outer blades to align with the deck in front-to-rear manner. Reposition rear mounting bolts up or down until rear of mower deck is positioned level to $\frac{1}{8}$ " higher in the rear than the side-to-side measurement.
4. Confirm measurements once again. Blade tips should be level in a side-to-side manner. In the rear, blade tips should be level to $\frac{1}{8}$ " higher than side-to-side measurement. In the front, blade tips should be level to $\frac{1}{8}$ " lower than side-to-side measurement.

NOTE: This will place the mower deck in a base measurement position. Additional adjustment may be required to achieve desired cut for the type of grass or conditions being mowed.

To adjust anti-scalp rollers

Deck has anti-scalp rollers.

Anti-scalp rollers are properly adjusted when they are just slightly off of the ground when the deck is at the desired cutting height in the operating position. Anti-scalp rollers then keep the deck in the proper position to help prevent scalping in most terrain conditions.

Adjust the deck to the desired cutting height (see "TO ADJUST DECK CUTTING HEIGHT" in the operation section of this manual).

Using a $\frac{3}{4}$ " wrench and a $\frac{9}{16}$ " wrench, remove the nut and shoulder bolt from the anti-scalp roller.

Lower the anti-scalp roller to the ground, and raise it up to the next highest hole.

Replace and tighten the nut and shoulder bolt.

Be sure to adjust all of the anti-scalp rollers to the same position.

Be sure to readjust the anti-scalp rollers if the cutting height is changed.

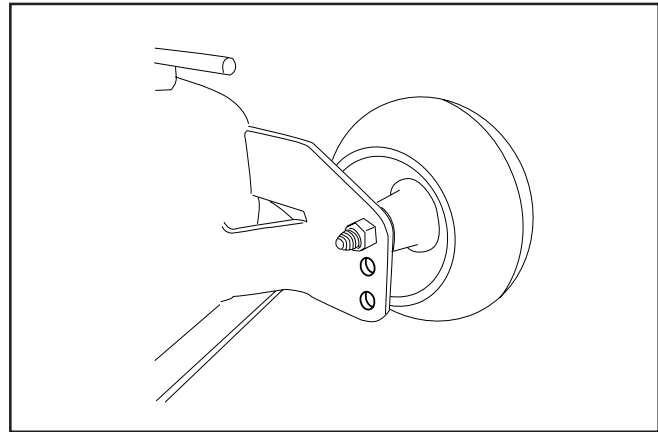

CZ9

Anti-scalp roller

IMPORTANT INFORMATION

The anti-scalp rollers must not be used for gauge wheels or the roller and deck may be damaged.

MAINTENANCE

Engine oil cooler

Kohler engine only.

1. Clean the outside of fins with a brush.
2. Remove the two screws holding the cooler unit to the blower housing.
3. Tilt the cooler downward.
4. Clean the inside of the cooler with a brush or with compressed air.
5. Reinstall the oil cooler to the blower housing.

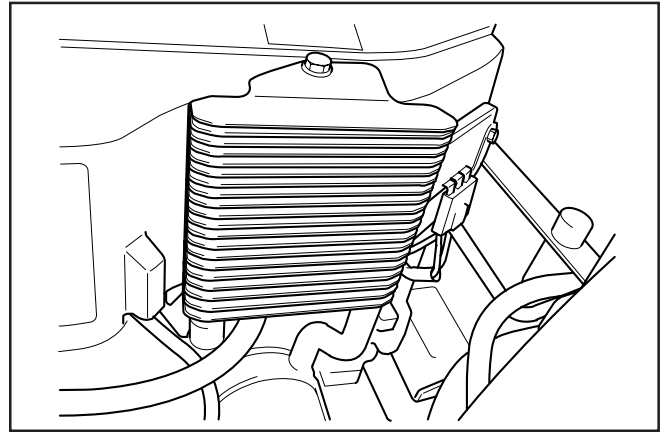

8011-472

Engine oil cooler

Cleaning and Washing

Regular cleaning and washing, especially under the mower deck, will increase the machine's lifespan. Make it a habit to clean the machine directly after use (after it is cooled), before the dirt sticks.

Do not spray water on the top of the mower deck. Use compressed air to clean the top side of mower deck. Regularly clean deck and underside of deck, avoid spraying engine and electrical components with water.



Use protective glasses when cleaning and washing.

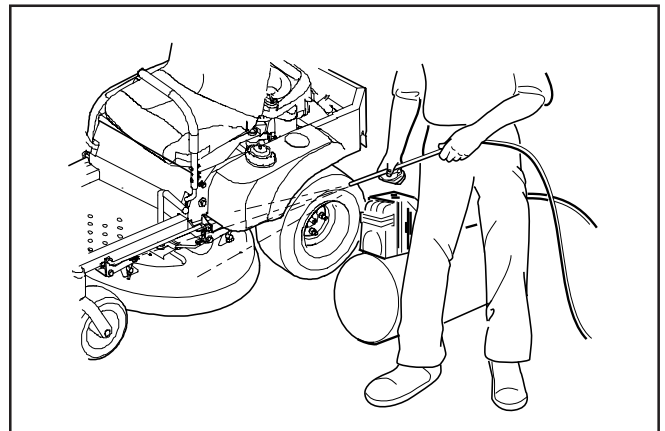

8050-092

Cleaning

Caster Wheels

Check every 200 hours. Lift front of unit off of ground so caster wheels can rotate freely. Tighten caster bolt then back off $\frac{1}{2}$ turn. Check that wheel rotates freely. If wheel does not rotate freely back the caster bolt off in $\frac{1}{4}$ turn increments until wheel rotates freely.

Foam filled tires or solid tires will void the warranty.

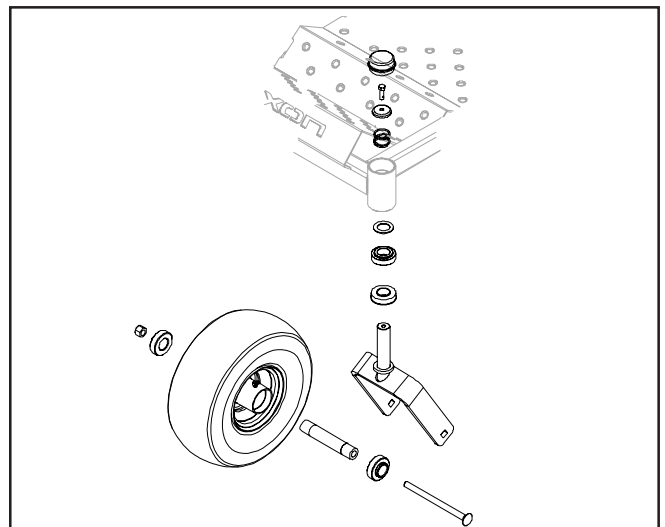

Caster wheels

Hardware

Check daily. Inspect the entire machine for loose or missing hardware.

LUBRICATION

12/12	1/52	1/365		25h	50h	100h	200h	300h	
				1 ← (2x)					
				2 ← (2x)					
				3 ←					
				4 ← (2x)					
(Y)	👁️	5		7 ← (2x)					
				6					
				5		👇			
				*					

8011-672-3

12/12 Every year
1/52 Every Week
1/365 Every day

Lubricate with grease gun
Oil change
Filter change

Lubricate with oil can
 Level check

***Change transaxles (transmission) filters.**

General

Remove the ignition key to prevent unintentional movements during lubrication.

When lubricating with an oil can, it must be filled with engine oil.

When lubricating with grease, unless otherwise stated, use a high grade molybdenum disulfide grease.

For daily use, the machine should be lubricated twice weekly.

Wipe away excess grease after lubrication.

It is important to avoid getting lubricant on the belts or the drive surfaces on the belt pulleys. Should this happen, attempt to clean them with spirits. If the belt continues to slip after cleaning, it must be replaced. Gasoline or other petroleum products must not be used to clean belts.

LUBRICATION

Lubricating the Cables

If possible, grease both ends of the cables and move the controls to end stop positions when lubricating. Refit the rubber covers on the cables after lubrication. Cables with sheaths will bind if they are not lubricated regularly. If a cable binds, it can disrupt operation.

If a cable binds, remove the cable and hang it vertically. Lubricate it with light engine oil until the oil begins to escape from the bottom.

Tip: Fill a small plastic bag with oil and tape it so that it seals against the sheath and allow the cable to hang vertically from the bag overnight. If you do not succeed in lubricating the cable, it must be replaced.

Lubricating in Accordance with the Lubrication Schedule

1. Front Wheel Mount

Lubricate with a grease gun, one zerk for each wheel mount, until the grease is forced out.

Use only good quality bearing grease.

Grease from well-known brand names (petrochemical companies, etc.) usually maintains a good quality.

2. Front Wheel Bearings

Lubricate with a grease gun, one zerk for each set of wheel bearings, until the grease is forced out.

Use only good quality bearing grease.

3. Deck spindle

Lower the cutting deck completely.

If you use grease gun without rubber hose, the foot plate must be removed.

Lubricate with a grease gun, one zerk, 2-3 strokes.

Use only good quality bearing grease.

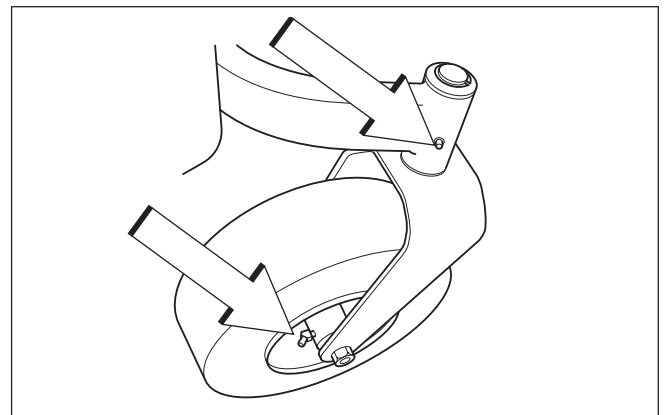

Lubricating the front wheels

8011-731

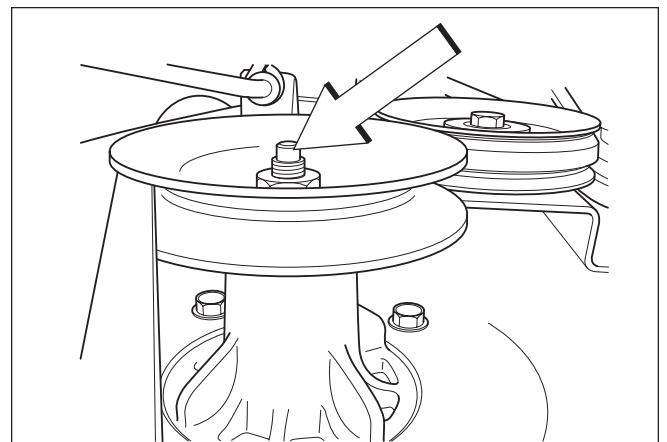

Deck spindle

8011-732

IMPORTANT INFORMATION

Use minimal lubrication and remove excess lubricant so that it does not come into contact with belts or belt pulley drive surfaces.

LUBRICATION

4. Deck outer spindle

Lubricate using a grease gun, one zerk, each side 2-3 strokes.

Use only good quality bearing grease.

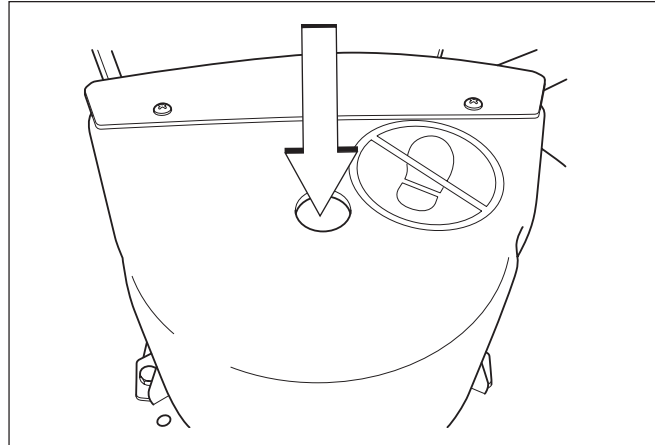

Deck outer spindle

8011-733

5. Engine Oil

Changing the Engine Oil

The engine oil should be changed for the first time after 5-8 hours of operation. Thereafter, it should be changed every 50 hours.



WARNING!

Engine oil can be very hot if it is drained directly after stopping the engine. Allow the engine to cool somewhat first.

IMPORTANT INFORMATION

Used engine oil is a health hazard and must not be disposed of on the ground or in nature; it should always be disposed of at a workshop or appropriate disposal location.

Avoid skin contact; wash with soap and water in case of spills.

1. Place the machine on a flat surface.
2. Place a container under the engine where the hose from the oil drain valve exits.
3. Remove the dipstick and open the drain valve.
4. Allow the oil to run out into the container.
5. Then close the oil drain valve.
6. Replace the oil filter if necessary.
7. Fill with new engine oil in accordance with Checking the Oil Level.
8. Start the engine. Run it for a few seconds. Stop and re-check the oil level.

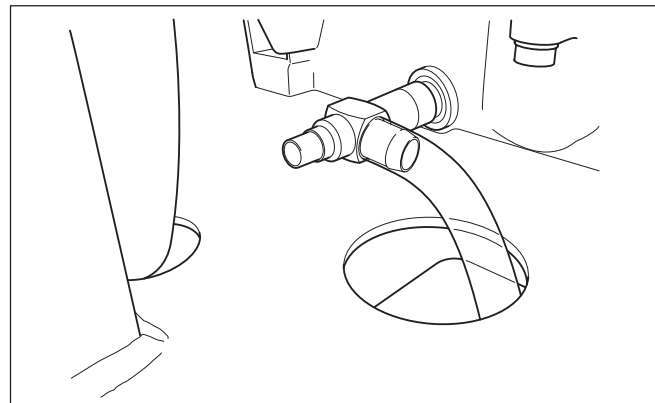

Oil drain valve

8011-730

LUBRICATION

Checking the Oil Level

Check the oil level in the engine when the machine is standing level and the engine is stopped.

Remove the dipstick, wipe it clean, and then replace it.

The dipstick should be screwed into place.

Take the dipstick out again and read the oil level.

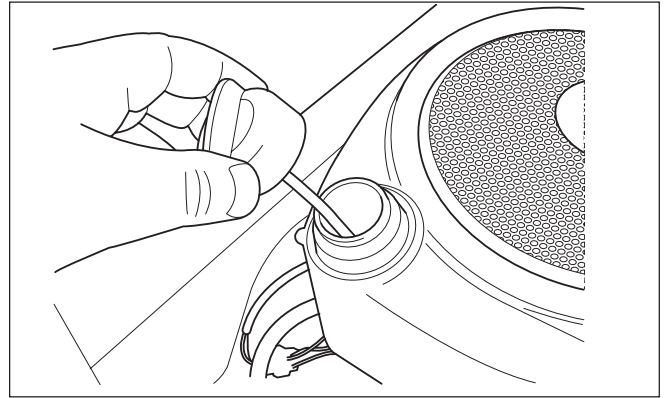

8011-500

Remove the dipstick

The oil level should lie between the markings on the dipstick. If the level is approaching the “ADD” mark, fill the oil to the “FULL” mark on the dipstick.

Never fill to above the “FULL” mark.

The oil is filled through the hole for the dipstick.

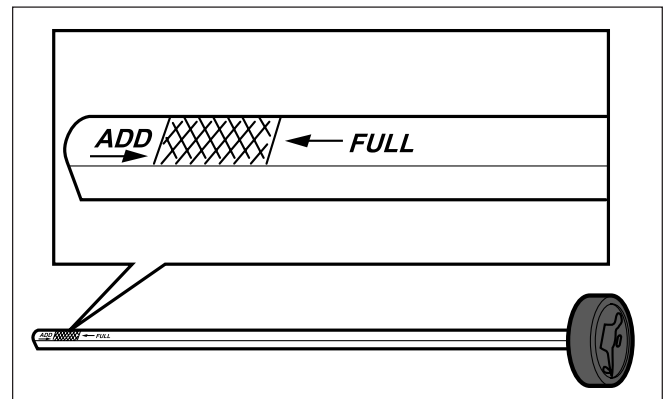

8009-159

The dipstick markings

API class SF, SG, SH, SJ or higher must be used.

Syntetic oil SAE 5W-30 or 10W-30 is recommended at all temperatures. Mineral oil SAE 5W-30, 10W-30 can be used between

-18 °C/0 °F and +5 °C/40 °F. At temperature above +5 °C/40 °F single grade SAE 30 must be used.

The engine holds 0.88 qt (1.0 liters) of oil excluding the filter, including filter 2 qt

(1.9 liters).

LUBRICATION

6. Changing the Engine Oil Filter

1. Drain the engine oil in accordance with the work description under the heading Engine Oil/Change Engine Oil.
2. Remove the oil filter. If necessary, use a filter remover.
3. Wipe new, clean engine oil onto the seal for the new filter.
4. Mount the filter by hand with $+ \frac{3}{4}$ turn.
5. Run the engine warm, then check that there are no leaks around the oil filter seal.
6. Check the oil level in the engine, fill if necessary. The oil filter holds
7. 0.1 qt (0.1 liters) of oil.

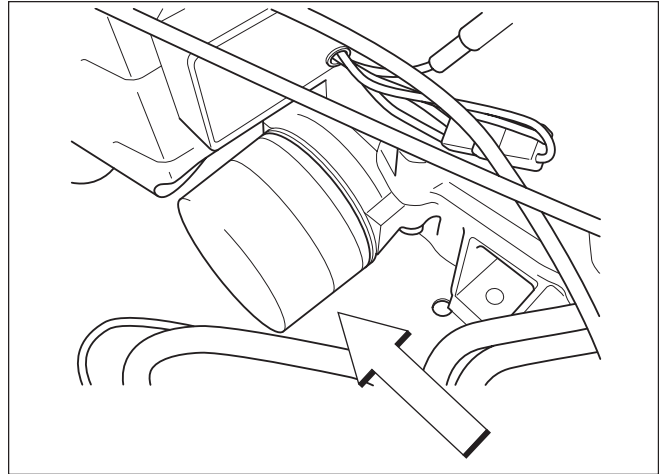

Changing the oil filter

8011-734

*Transaxle (Transmission) Fluid Change

This transaxle is designed with an external filter for ease of maintenance. To ensure constant fluid quality levels and longer life an oil filter change interval of every 200 hours is recommended.

The following procedure can be performed with the transaxles installed in the vehicle, and the vehicle on level ground. Apply the bypass valve for each transaxle and lock the vehicle parking brake.

1. Remove the three $\frac{1}{4}$ " filter guard screws and filter guard. Clean any loose debris from around the perimeter of the filter. See illustrations.
2. Place an oil drain pan 12" or more diameter and 8 qt. capacity is optimal) beneath the oil filter. Remove the oil filter from the transaxle.
3. After the oil has drained, wipe the filter base surface off and apply a film of new oil to the gasket of the new replacement filter.
4. Install the new filter by hand, turn $\frac{3}{4}$ to one full turn after the filter gasket contacts the filter base surface.
5. Re-install the filter guard with the three $\frac{1}{4}$ " screws. Torque screws to 65 in/lbs. each.
6. Repeat steps on the opposite side of transaxle drive.

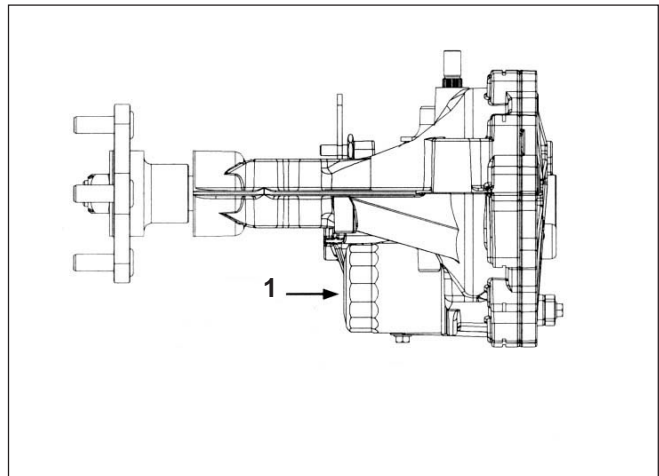

1. Filter (guard removed)

Changing the oil filter

8019-011

LUBRICATION

7. Drain old oil filters of all free flowing oil prior to disposal. Place used oil in appropriate containers and dispose of it in accordance with laws in your area.
8. Remove the top port plug (see illustration) from the left side and right side of the transaxles prior to filling with oil. This will allow the transaxles to vent during oil fill.
9. Remove the cap from the transaxles' expansion tank located on the vehicle frame.
10. Fill with 20W50 motor oil until oil just appears at the bottom of each transaxles' top port (approximately 2 quarts per transaxle, 4 quarts total). Install the top port plug into each transaxle as the oil level reaches this port.
11. Install and torque the top port plugs to 180 in./lbs.
12. Continue to fill the transaxles through the expansion tank until the "Full Cold" line is reached (this will take approximately 23 additional ounces).
13. Re-install the expansion tank cap by hand. Be careful to not overtighten.
14. Proceed to the purge procedure.

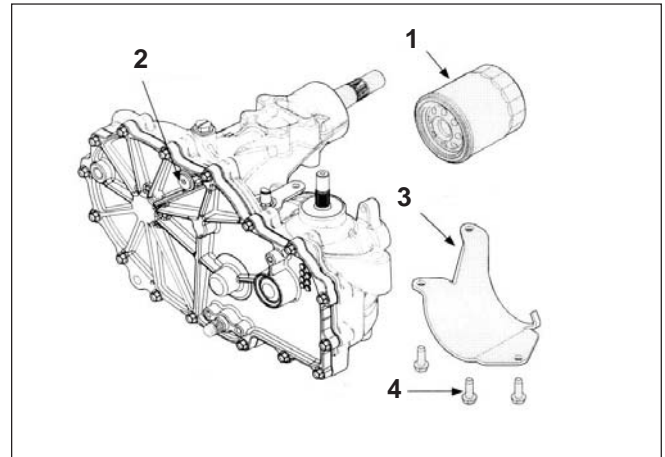

1. Filter
2. Top Port Plug
3. Filter Guard
4. Screws

8019-010

Changing the oil filter

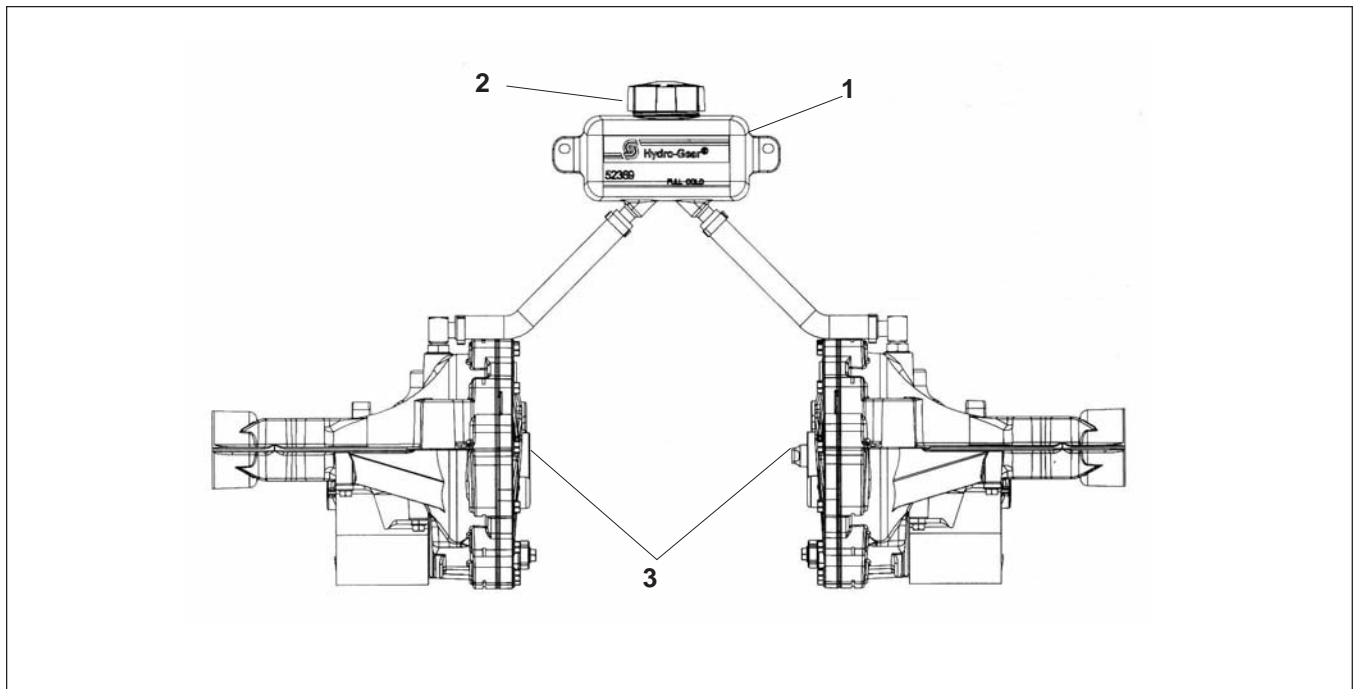

1. Expansion Tank
2. Cap
3. Transaxles

8019-012

Expansion Tank

LUBRICATION

Purging Procedures

Due to the effects air has on efficiency in hydrostatic drive applications, it is critical that it is purged from the system.

These purge procedures should be implemented any time a hydrostatic system has been opened to facilitate maintenance or any additional oil has been added to the system.

The resulting symptoms in hydrostatic systems may be:

1. Noisy operation.
2. Lack of power or drive after short term operation.
3. High operation temperature and excessive expansion of oil.

Before starting, make sure the transaxle is at the proper oil level. If it is not, fill to the specifications outlined earlier.

The following procedures are best performed with the vehicle drive wheels off the ground. Then repeated under normal operating conditions.

1. Disengage the brake if activated.
2. With the bypass valve open and the engine running at fast idle, slowly move the directional control in both forward and reverse directions (5 or 6 times). As air is purged from the unit, the oil level will drop.
3. With the bypass valve closed and the engine running, slowly move the directional control in both forward and reverse directions (5 to 6 times). Check the oil level, and add oil as required after stopping the engine.
4. It may be necessary to repeat Steps 2 and 3 until all the air is completely purged from the system. When the transaxle operates at normal noise levels and moves smoothly forward and reverse at normal speeds, then the transaxle is considered purged.
5. After the vehicle has been used two times, the oil level should be checked while the oil is cold and adjusted accordingly.

TROUBLE SHOOTING GUIDE

Trouble Shooting Guide

Problem	Cause
The engine will not start.	<ul style="list-style-type: none">• The blade switch is engaged.• The steering controls are not locked in the neutral position.• The driver is not sitting in the driver's seat.• The parking brake is not activated.• The battery is dead.• Contamination in the carburetor or fuel line.• The fuel supply is closed or the shut-off valve for the fuel tank is in the wrong position.• Clogged fuel filter or fuel line.
The starter does not turn the engine over.	<ul style="list-style-type: none">• Dead battery.• Poor contacts on the battery terminal cable connections.• Fuse blown.• Ignition system faulty.• Fault in the starter safety circuit. See Checking the Safety System in the "Maintenance Section,"
The engine runs rough.	<ul style="list-style-type: none">• Faulty carburetor.• The choke control is pulled out with a warm engine.• Defective valves.• Defective piston, cylinder, piston ring, or cylinder head seal.• The cylinder head bolts are loose.• Clogged fuel filter or jet.• Clogged ventilation valve on the fuel cap.• Fuel tank nearly empty.• Defective spark plugs.• The spark plugs are loose.• Defective ignition cable.• Defective spark plug electrode.• Defective spark plug connection.• Rich fuel mixture or fuel-air mixture.• Wrong fuel type.• Water in the fuel.• Clogged air filter.• Air trapped in hydraulic system.

TROUBLE SHOOTING GUIDE

The engine seems weak.

- Clogged air filter.
- Defective spark plugs.
- Carburetor incorrectly adjusted.
- Air trapped in hydraulic system.

The engine overheats.

- Clogged air intake or cooling fins.
- Engine overloaded.
- Poor ventilation around engine.
- Defective engine speed regulator.
- Soot in the combustion chamber.
- Too little or no oil in the engine.
- Defective spark plugs.
- Pre-ignition incorrect.

Battery not charging.

- Poor contact with battery terminal cable connectors.

The machine moves slowly, unevenly, or not at all.

- Parking brake on.
- Bypass valve on pump open.
- Drive belt for the transmission gears slack or has come off.
- Air trapped in hydraulic system.

Mower deck not engaging.

- Drive belt for the mower deck has come loose.
- Contact for the electromagnetic coupling has loosened.
- The blade switch is faulty or has come loose, from the cable contact.
- The fuse has blown.

Transaxle leaks oil.

- Damaged seals, housing, or gaskets.
- Air trapped in hydraulic system.

TROUBLE SHOOTING GUIDE

Uneven mowing results.

- Different air pressure in the tires on the left and right sides.
- Bent blades.
- The suspending for the mower deck is uneven.
- The chain fixture has come loose.
- The blades are blunt.
- Driving speed too high.
- The grass is too long.
- Grass collected under the mower deck.

The machine vibrates.

- The blades are loose.
 - The blades are incorrectly balanced.
 - The engine is loose.
-

STORAGE

Storage

Winter Storage

At the end of the mowing season, the machine should be readied for storage (or if it will not be in use for longer than 30 days). Fuel allowed to stand for long periods of time (30 days or more) can leave sticky residues that can plug the carburetor and disrupt engine function.

Fuel stabilizers are an acceptable option as regards to the sticky residues that can occur during storage.

Add stabilizer to the fuel in the tank or in the storage container. Always use the mixing ratios specified by the manufacturer of the stabilizer. Run the engine for at least 10 minutes after adding the stabilizer so that it reaches the carburetor. Do not empty the fuel tank and the carburetor if you have added stabilizer



WARNING!

Never store an engine with fuel in the tank indoors or in poorly ventilated spaces where fuel vapor can come in contact with open flames, sparks, or a pilot light such as in a boiler, hot water tank, clothes drier, etc. Handle the fuel with care. It is very flammable and can cause serious personal injury and property damage. Drain the fuel into an approved container outdoors and far away from open flame. Never use gasoline for cleaning. Use a degreaser and warm water instead.

To ready the machine for storage, follow these steps:

1. Thoroughly clean the machine, especially under the mower deck. Touch up damage to the paint and spray a thin layer of oil on the underside of the mower deck to avoid corrosion.
2. Inspect the machine for worn or damaged parts and tighten any nuts or screws that may have become loose.
3. Change the engine oil; dispose of properly.
4. Empty the fuel tanks or add a fuel stabilizer. Start the engine and allow it to run until the carburetor is drained of fuel or the stabilizer has reached the carburetor.
5. Remove the spark plug and pour about a tablespoon of engine oil into the cylinder. Turn over the engine so that the oil is evenly distributed and then refit the spark plug.
6. Lubricate all grease zerks, joints, and axles.
7. Remove the battery. Clean, charge, and store the battery in a cool place, but protect it from direct cold.
8. Store the machine in a clean, dry place and cover it for extra protection.

Service

When ordering spare parts, please specify the purchase year, model, type, and serial number.

Always use genuine Dixon spare parts.

An annual check-up at an authorized service workshop is a good way to ensure that your machine performs its best the following season.

SCHEMATIC

FRONT HALF OF WIRING HARNESS ALL MODELS

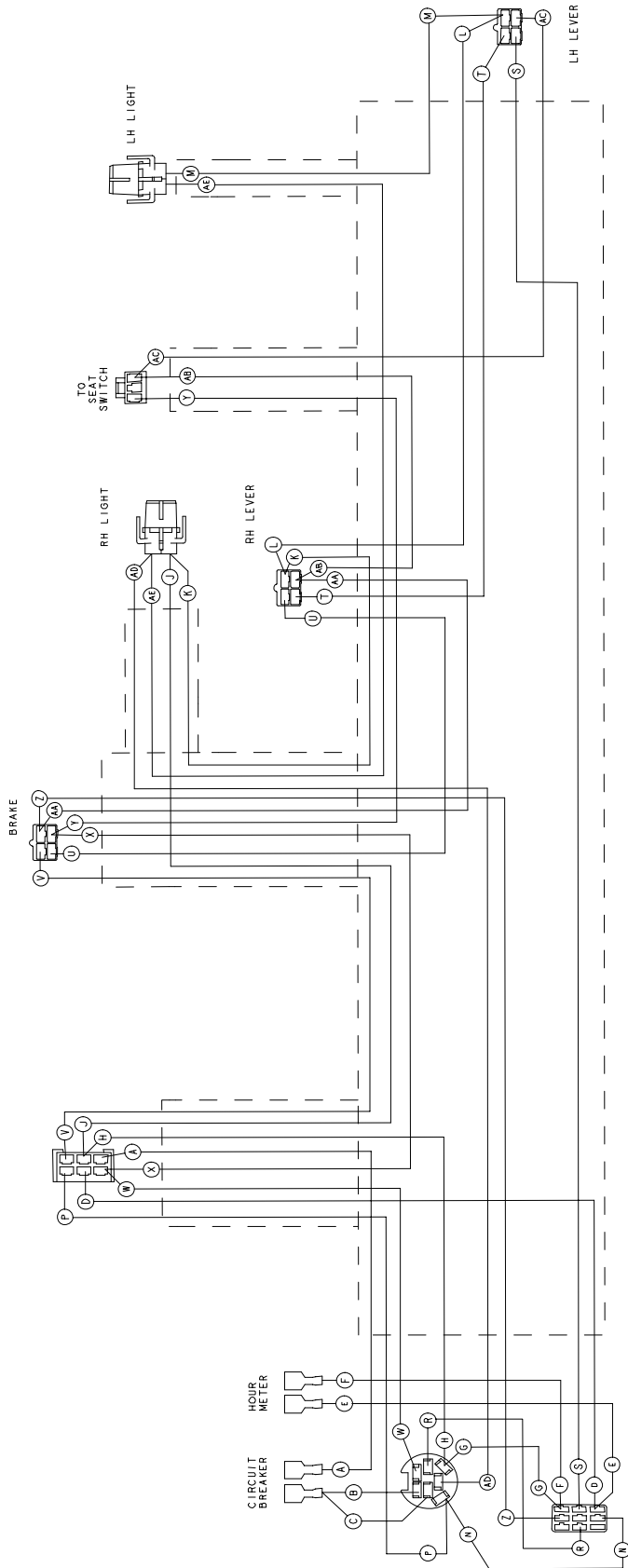

CODE	COLOR
A	RED
B	RED
C	RED
D	BLBLUE
E	BLUE
F	WHITE
G	WHITE
H	WHITE
J	WHITE
K	WHITE
L	WHITE
M	WHITE
N	RED/WHT
P	RED/WHT
R	YELLOW
S	YELLOW
T	YELLOW
U	YELLOW
V	YELLOW
W	GREEN
X	GREEN
Y	GREEN
Z	WHT/GRN
AA	WHT/GRN
AB	WHT/GRN
AC	WHT/GRN
AD	BROWN
AE	BROWN

SCHEMATIC

REAR HARNESS MODELS: 968999564, 968999565, 968999618

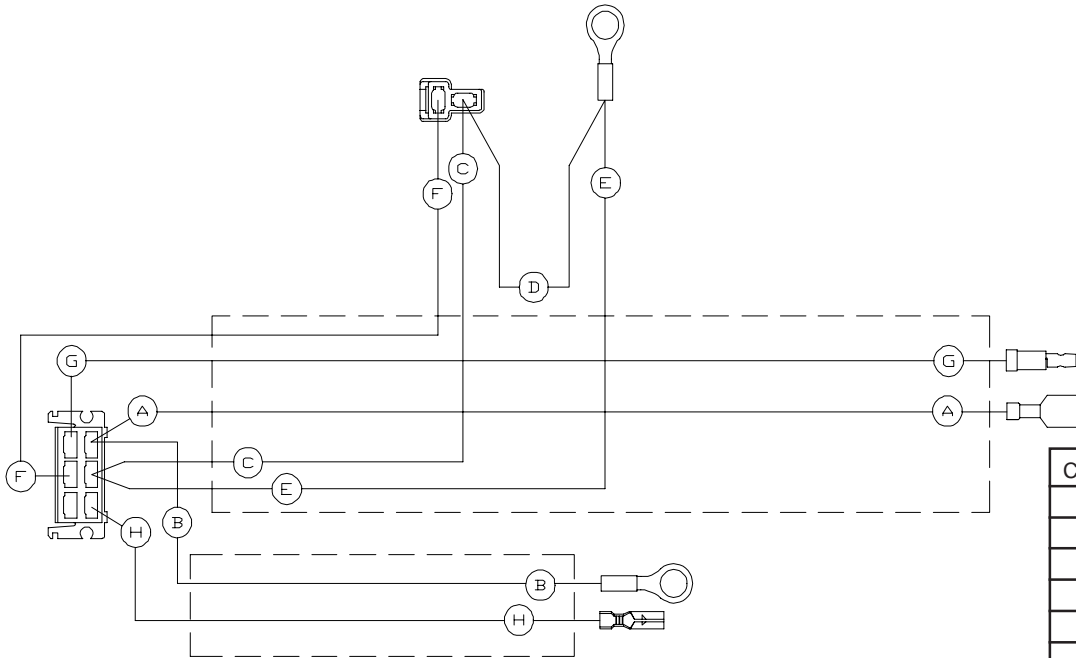

CODE	COLOR
A	RED
B	RED
C	RED
D	RED/WHT
E	WHITE
F	WHITE
G	WHITE
H	WHITE
J	YELLOW
K	YELLOW
L	GREEN
M	BLUE

REAR HARNESS MODELS: 968999566, 968999619

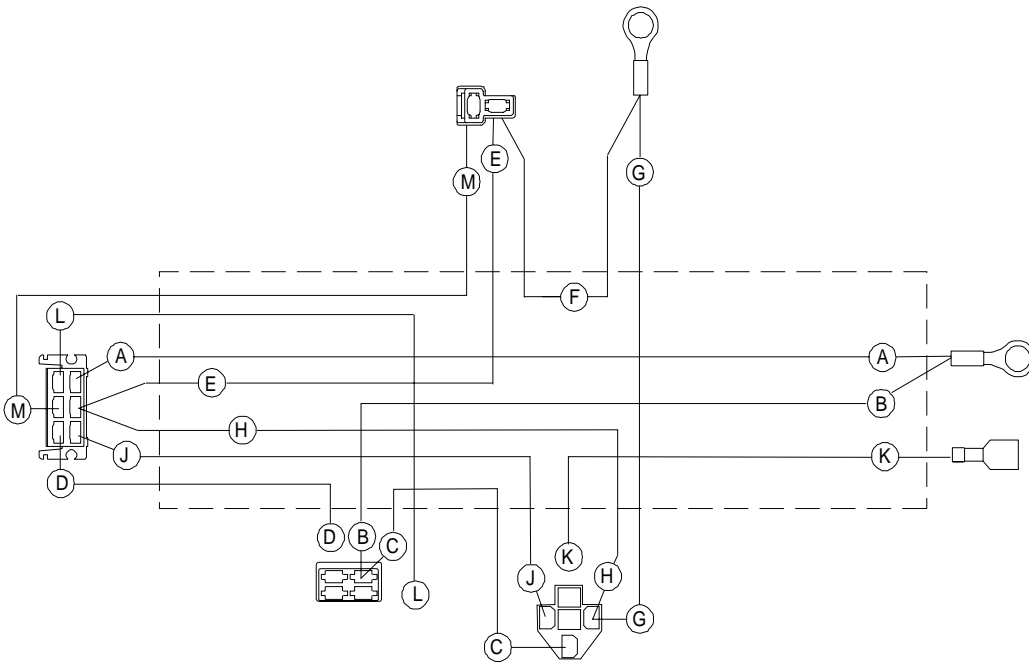

CODE	COLOR
A	RED
B	RED
C	WHITE
D	WHITE
E	WHITE
F	BLUE
G	GREEN
H	YELLOW

SCHEMATIC

REAR WIRING HARNESS MODELS: 968999690, 968999731

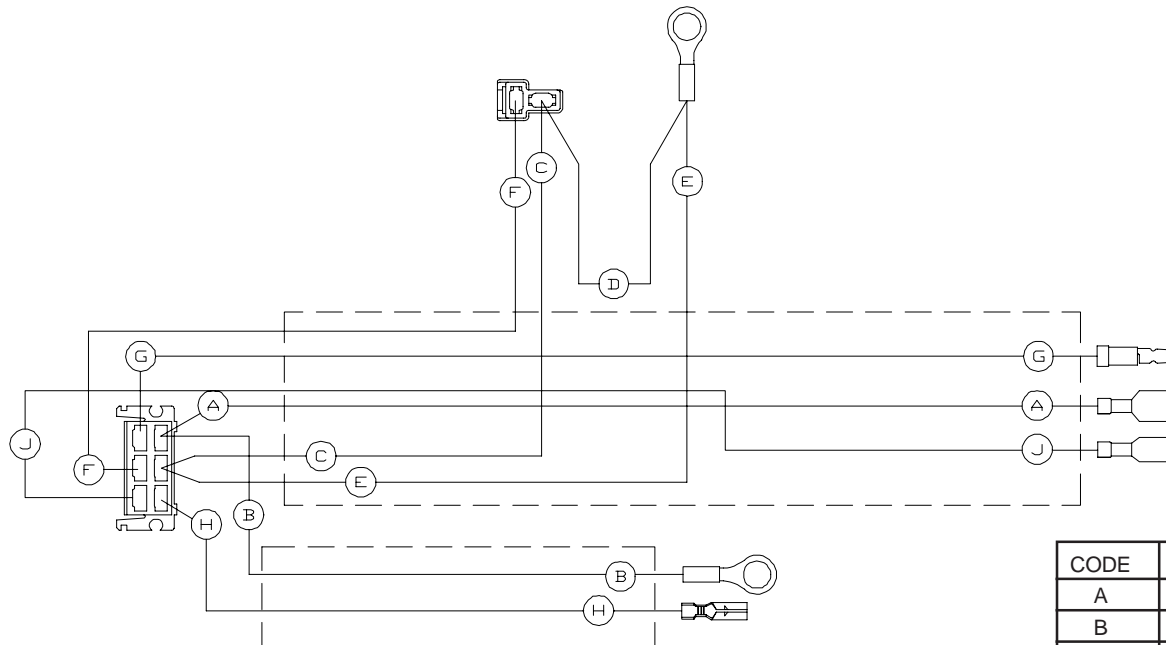

CODE	COLOR
A	RED
B	RED
C	WHITE
D	WHITE
E	WHITE
F	BLUE
G	GREEN
H	YELLOW
J	RED/WHT

TECHNICAL DATA

Technical Data

	BLACK BEAR 34/ 968999564	BLACK BEAR 44/ 968999565
Engine		
Manufacturer	Kohler	Kohler
Type	Command Pro	Command Pro
Power	18 hp	18 hp
Lubrication	Pressure with oil filter	Pressure with oil filter
Oil capacity excl filter	1.9 (1.8 liters)	1.9 (1.8 liters)
Oil capacity incl filter	2 qt (1.9 liters)	2 qt (1.9 liters)
Engine oil, Synthetic	10W-30, 5W-20/5W-30 synthetic(winter)	10W-30, 5W-20/5W-30 synthetic(winter)
Engine oil, Mineral Class	SG, SH, SJ	SG, SH, SJ
Fuel	87 octane minimum 10% ethanol max. 15% MTBE by volume	87 octane minimum 10% ethanol max. 15% MTBE by volume
Fuel tank capacity	4.5 gallon (17 liters)	4.5 gallon (17 liters)
Spark plugs/gap	RC12YC .040" / 1.02 mm	RC12YC .040" / 1.02 mm
Cooling	Air cooling	Air cooling
Air filter	Standard	Standard
Alternator	12V 16A	12V 16A
Starter	Electric 12V	Electric 12V
Transmission		
Transmission	ZT2800 Hydro-Gear	Zt2800 Hydro-Gear
Speed and direction controls	Dual levers, foam gripped	Dual levers, foam gripped
Speed forward	8 mph	8 mph
Speed reverse	5 mph	5 mph
Brakes	Mechanical parking brake	Mechanical parking brake
Front caster tires, smooth tread	11x4.5-5, 4 ply	11x4.5-5, 4 ply
Rear tires, Turf pneumatic	23 X 8.5-12	23 X 8.5-12
Tire pressure, front and rear	15 PSI / 103 kPa / 1 bar	15 PSI / 103 kPa / 1 bar

TECHNICAL DATA

	BLACK BEAR 34/ 968999564	BLACK BEAR 44/ 968999565
Equipment		
Cutting width	34"	44"
Cutting height	1.5" - 4.5"	1.5" - 4.5"
Uncut circle	0	0
Number of blades	2	3
Blade length	17.38"	15.25"
Nose rollers	Yes	Yes
American Craftsmen Seat	Standard	Standard
Hinged armrests	Yes	Yes
Hour meter	Standard	Standard
Blade engagement	Electric clutch	Electric clutch
Deck construction	7 gauge w/7 gauge skirts	7 gauge w/7 gauge skirts
Productivity		
Productivity	2.75 acres/hr	3.56 acres/hr
Overall dimensions		
Weight	650 lbs. (295 kg)	675 lbs. (308 kg)
Base machine length	71" (180 cm)	71" (180 cm)
Base machine width	33 7/8" (cm)	45½" (116 cm)
Base machine height	46" (117 cm)	46" (117 cm)
Overall width, chute up	35" (89 cm)	44.5" (113 cm)
Overall width, chute down	44½" (113 cm)	54" (137 cm)

TECHNICAL DATA

Technical Data

	BLACK BEAR 34/ 968999566	BLACK BEAR 34/ 968999618
Engine		
Manufacturer	Kawasaki	Kohler
Type	KAI	Command Pro
Power	16 hp	18 hp
Lubrication	Pressure with oil filter	Pressure with oil filter
Oil capacity excl filter	1.6 qt (1.5 liters)	1.9 (1.8 liters)
Oil capacity incl filter	1.8 qt (1.7 liters)	2 qt (1.9 liters)
Engine oil, Synthetic	SAE3 30, 10W-30/10W-40	10W-30, 5W-20/5W-30 (winter)
Engine oil, Mineral Class	SAE, 5W-20 (winter) SF, SG, SH, SJ	SG, SH, SJ
Fuel	87 octane minimum 10% max. ethanol 15% MTBE by volume 5% max. methanol	87 octane minimum 10% max. ethanol 15% MTBE by volume
Fuel tank capacity	4.5 gallon (17 liters)	4.5 gallon (17 liters)
Spark plugs/gap	Champion RCJ8Y .030" / 0.75 mm	RC12YC .040" / 1.02 mm
Cooling	Air cooling	Air cooling
Air filter	Standard	Standard
Alternator	12V 16A	12V 16A
Starter	Electric 12V	Electric 12V
Transmission		
Transmission	ZT2800 Hydro-Gear	ZT2800 Hydro-Gear
Speed and direction controls	Dual levers, foam gripped	Dual levers, foam gripped
Speed forward	8 mph	8 mph
Speed reverse	5 mph	5 mph
Brakes	Mechanical parking brake	Mechanical parking brake
Front caster tires, smooth tread	11x4.5-5, 4 ply	11x4.5-5, 4 ply
Rear tires, Turf pneumatic	23 X 8.5-12	23 X 8.5-12
Tire pressure, front and rear	15 PSI / 103 kPa / 1 bar	15 PSI / 103 kPa / 1 bar

TECHNICAL DATA

	BLACK BEAR 34/ 968999566	BLACK BEAR 34/ 968999618
Equipment		
Cutting width	34"	34"
Cutting height	1.5" - 4.5"	1.5" - 4.5"
Uncut circle	0	0
Number of blades	2	2
Blade length	17.38"	17.38"
Nose rollers	Yes	Yes
Michigan Seat	Standard	Standard
Hinged armrests	Yes	Yes
Hour meter	Standard	Standard
Blade engagement	Electric clutch	Electric clutch
Deck construction	7 gauge w/7 gauge skirts	7 gauge w/7 gauge skirts
Productivity		
Productivity	2.75 acres/hr	2.75 acres/hr
Overall dimensions		
Weight	650 lbs. (295 kg)	650 lbs. (295 kg)
Base machine length	71" (180 cm)	71" (180 cm)
Base machine width	33 ⁷ / ₈ " (73 cm)	33 ⁷ / ₈ " (73 cm)
Base machine height	46" (117 cm)	46" (117 cm)
Overall width, chute up	35" (89 cm)	35" (89 cm)
Overall width, chute down	44 ¹ / ₂ " (113 cm)	44 ¹ / ₂ " (113 cm)

TECHNICAL DATA

Technical Data

	BLACK BEAR 34/ 968999619	BLACK BEAR 44/ 968999690
Engine		
Manufacturer	Kawasaki	Kawasaki
Type	KAI	KAI
Power	16 hp	19 hp
Lubrication	Pressure with oil filter	Pressure with oil filter
Oil capacity excl filter	1.7 qt (1.6 liters)	1.6 qt (1.5 liters)
Oil capacity incl filter	1.9 qt (1.8 liters)	1.8 qt (1.7 liters)
Engine oil, Synthetic Engine oil, Mineral Class	SAE 30, 10w-30/10w-40 SAE 5W-20 (winter) SF, SG, SH, SJ	SAE 30, 10w-30/10w-40 SAE 5W-20 (winter) SF, SG, SH, SJ
Fuel	87 octane minimum 10% max. ethanol 15% MTBE by volume 5% max. methanol	87 octane minimum 10% max. ethanol 15% MTBE by volume 5% max. methanol
Fuel tank capacity	4.5 gallon (17 liters)	4.5 gallon (17 liters)
Spark plugs/gap	Champion RCJ8Y .030" / 0.75 mm	Champion RCJ8Y .030" / 0.75 mm
Cooling	Air cooling	Air cooling
Air filter	Standard	Standard
Alternator	12V 16A	12V 16A
Starter	Electric 12V	Electric 12V
Transmission		
Transmission	ZT2800 Hydro-Gear	ZT2800 Hydro-Gear
Speed and direction controls	Dual levers, foam gripped	Dual levers, foam gripped
Speed forward	8 mph	8 mph
Speed reverse	5 mph	5 mph
Brakes	Mechanical parking brake	Mechanical parking brake
Front caster tires, smooth tread	11x4.5-5, 4 ply	11x4.5-5, 4 ply
Rear tires, Turf pneumatic	23 X 8.5-12	23 X 8.5-12
Tire pressure, front and rear	15 PSI / 103 kPa / 1 bar	15 PSI / 103 kPa / 1 bar

TECHNICAL DATA

	BLACK BEAR 34/ 968999619	BLACK BEAR 44/ 968999690
Equipment		
Cutting width	34"	44"
Cutting height	1/5" - 4.5"	1/5" - 4.5"
Uncut circle	0	0
Number of blades	2	3
Blade length	17.38"	15.25"
Nose rollers	Yes	Yes
Michigan Seat	Standard	Standard
Hinged armrests	Yes	Yes
Hour meter	Standard	Standard
Blade engagement	Electric clutch	Electric clutch
Deck construction	7 gauge w/7 gauge skirts	7 gauge w/7 gauge skirts
Productivity		
Productivity	2.75 acres/hr	3.56 acres/hr
Overall dimensions		
Weight	650 lbs. (295 kg)	675 lbs. (308 kg)
Base machine length	71" (180 cm)	71" (180 cm)
Base machine width	33 ⁷ / ₈ " (73 cm)	33 ⁷ / ₈ " (73 cm)
Base machine height	46" (117 cm)	46" (117 cm)
Overall width, chute up	35" (89 cm)	44.5" (113 cm)
Overall width, chute down	44 ¹ / ₂ " (113 cm)	54" (137 cm)

TECHNICAL DATA

Technical Data

	BLACK BEAR 34/ 968999731
Engine	
Manufacturer	Kawasaki
Type	KAI
Power	16 hp
Lubrication	Pressure with oil filter
Oil capacity excl filter	1.9 (1.8 liters)
Oil capacity incl filter	2 qt (1.9 liters)
Engine oil, Synthetic	SAE 30, 10w-30/10w-40
Engine oil, Mineral Class	SAE 5W-20 (winter) SF, SG, SH, SJ
Fuel	87 octane minimum 10% max. ethanol 15% MTBE by volume 5% max. methanol
Fuel tank capacity	4.5 gallon (17 liters)
Spark plugs/gap	Champion RXJ8Y .030" / 0.75 mm
Cooling	Air cooling
Air filter	Standard
Alternator	12V 16A
Starter	Electric 12V
Transmission	
Transmission	ZT2800 Hydro-Gear
Speed and direction controls	Dual levers, foam gripped
Speed forward	8 mph
Speed reverse	5 mph
Brakes	Mechanical parking brake
Front caster tires, smooth tread	11x4.5-5, 4 ply
Rear tires, Turf pneumatic	23 X 8.5-12
Tire pressure, front and rear	15 PSI / 103 kPa / 1 bar

TECHNICAL DATA

BLACK BEAR 34/ 968999731	
Equipment	
Cutting width	34"
Cutting height	1.5" - 4.5"
Uncut circle	0
Number of blades	2
Blade length	17.38"
Nose rollers	Yes
Michigan Seat	Standard
Hinged armrests	Yes
Hour meter	Standard
Blade engagement	Electric clutch
Deck construction	7 gauge w/7 gauge skirts
Productivity	
Productivity	2.75 acres/hr
Overall dimensions	
Weight	650 lbs. (295 kg)
Base machine length	71" (180 cm)
Base machine width	33 ⁷ / ₈ " (73 cm)
Base machine height	46" (117 cm)
Overall width, chute up	35" (89 cm)
Overall width, chute down	44 ¹ / ₂ " (113 cm)

TECHNICAL DATA

Accessories

Collection system

Torque Specifications

·Engine crankshaft bolt	50 ft/lb (67 Nm)
·Deck pulley bolts	45 ft/lb (61 Nm)
·Lug nuts	75 ft/lb (100 Nm)
·Blade bolt	45-55 ft/lb (60-75 Nm)
·Standard ¼" fasteners	9 ft/lb (12 Nm)
·Standard 5/16" fasteners	18 ft/lb (25 Nm)
·Standard 3/8" fasteners	33 ft/lb (44 Nm)
·Standard 7/16" fasteners	52 ft/lb (70 Nm)
·Standard ½" fasteners	80 ft/lb (110 Nm)

When this product is worn out and no longer used, it should be returned to the reseller or other party for recycling.

In order to implement improvements, specifications and designs can be altered without prior notification.

Note that no legal demands can be placed based on the information contained in these instructions.

Use only original parts for repairs. The use of other parts voids the warranty.

Do not modify or install non-standard equipment to the unit without consent from the manufacturer. Modifications to the unit may cause unsafe operations or damage the unit.

CONFORMITY CERTIFICATES

Conformity Certificates

USA requirements

Labels are placed on the engine and/or in the engine compartment stating that the machine will fulfill the requirements. This is also applicable to special requirements for any of the states, (Californian emission rules etc.). Do not remove any of these labels. Certificates can also be supplied with the machine at delivery or written in the Engine manual. Take care of them as they are valuable documents.

CE requirements

Vibration data corresponding to Directive 2002/44/EC is given in the Technical Data Section.
The Declaration of Conformity is included in the literature packet.

SERVICE JOURNAL

Service Journal

Action	Date, mtr reading, stamp, sign
Delivery Service	
1. Charge the battery.	<input type="checkbox"/>
2. Adjust the tire pressure of all wheels to 15 PSI (1 bar).	<input type="checkbox"/>
3. Mount the steering controls in the normal position.	<input type="checkbox"/>
4. Connect the contact box to the cable for the seat's safety switch.	<input type="checkbox"/>
5. Check that the right amount of oil is in the engine.	<input type="checkbox"/>
6. Adjust the position of the steering controls.	<input type="checkbox"/>
7. Fill with fuel and open the fuel shut off valve.	<input type="checkbox"/>
8. Start the engine.	<input type="checkbox"/>
9. Check that there is drive to both wheels.	<input type="checkbox"/>
10. Check the mower deck adjustment.	<input type="checkbox"/>
11. Check:	
The safety switch for the parking brake.	<input type="checkbox"/>
The safety switch for the mower deck.	<input type="checkbox"/>
The safety switch in the seat.	<input type="checkbox"/>
The safety switch in the steering controls.	<input type="checkbox"/>
Parking brake functionality.	<input type="checkbox"/>
Driving forward.	<input type="checkbox"/>
Driving backward.	<input type="checkbox"/>
Engaging the blades.	<input type="checkbox"/>
12. Check the idle speed	<input type="checkbox"/>
13. Check the engine high idle speed	<input type="checkbox"/>
14. Inform the customer about:	
The need and advantages of following the service schedule.	Delivery service has been carried out.
The need and advantages of leaving the machine for service every 300 hours.	No remaining notes.
The effects of service and maintaining a service journal on the machine's resale value.	Certified:
Application areas for Mulching.	
15. Fill in the sales papers, etc.	

SERVICE JOURNAL

After the First 5-8 Hours	
----------------------------------	--

1. Change engine oil.

SERVICE JOURNAL

Action	Date, mtr reading, stamp, sign
<p>25-Hour Service</p> <ol style="list-style-type: none">1. Check the fuel pump's air filter.2. Sharpen/Replace mower blades if required.3. Check the tire pressures.4. Check battery with cables.5. Lubricate according to lubrication chart.6. Check/clean the engine's cooling air intake.7. Clean the air cleaner's pre-filter (foam).	

SERVICE JOURNAL

Action	Date, mtr reading, stamp, sign
<p>50-Hour Service</p> <ol style="list-style-type: none">1. Perform the 25-hour service.2. Clean/replace the air cleaner's filter cartridge (paper filter) (shorter intervals for dusty operating conditions).3. Change engine oil.4. Lubricate according to lubrication chart.5. Check/adjust the parking brake.	

SERVICE JOURNAL

Action	Date, mtr reading, stamp, sign
<p>100-Hour Service</p> <ol style="list-style-type: none">1. Perform the 25-hour service.2. Perform the 50-hour service.3. Change the engine oil filter.4. Clean/replace the spark plugs.5. Replace the fuel filter.6. Clean the cooling fins on the engine and transmission.7. Check V-belts.8. Check tighten caster wheel axle bolts (every 200 hours).9. Change the air filter's paper cartridge.	

SERVICE JOURNAL

Action	Date, mtr reading, stamp, sign
<p>300-Hour Service</p> <ol style="list-style-type: none">1. Inspect the machine. Come to agreement with the customer as to which additional work is to be carried out.2. Perform the 25-hour service.3. Perform the 50-hour service.4. Perform the 100-hour service.5. Check/adjust the mower deck.6. Clean the combustion chamber and grind the valve seats.7. Check the engine valve clearance.8. Replace the air cleaner's pre-filter (foam).	

SERVICE JOURNAL

Action	Date, mtr reading, stamp, sign
<p>At Least Once Each Year</p> <ol style="list-style-type: none">1. Clean the engine's cooling air intake (25 hours).2. Replace the air cleaner's pre-filter (foam) (300 hours).3. Replace the air filter's paper cartridge.4. Change the engine oil (50 hours).5. Replace the engine oil filter (100 hours).6. Check/adjust the cutting height.7. Check/adjust the parking brake (50 hours).8. Clean/Change the spark plugs (100 hours).9. Change the fuel filter (100 hours).10. Clean the cooling fins (100 hours).11. Check the engine valve clearance.12. Perform the 300-hour service at an authorized service workshop.	

SERVICE JOURNAL

Action	Date, mtr reading, stamp, sign

DIXON ZTR

Part No. 539 118101 R01 (08/14/07)